



XC Series

**Lithium Battery
Counterbalance
d Forklift Truck**

CPD15/18/20/25/30/35/38-XCY2-SI
CPD20/25/27/30/35-XCY2H-SI
CPD20-XCXY2-SI

Operation and Maintenance Manual

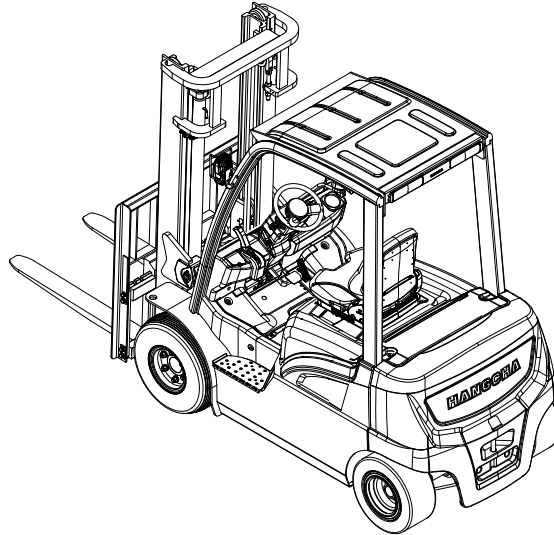

Original Instruction

HANGCHA GROUP CO., LTD.
Nov. 2023

Foreword

Thank you very much for purchasing lithium battery counterbalanced forklift truck of Hangcha Group.

Before using the truck, relative persons must read and understand the manual, get to know how to safely operate and maintain the truck.

XC series four-wheel lithium battery counterbalanced forklift truck is a new product with small turning radius, attractive design, compact structure, small size, low centre of gravity, good stability and superior performance. 采用永磁电机，结构简单，可靠性高，效率高。

This manual is about the brief introduction and correct operation of the XC series four-wheel lithium battery counterbalanced forklift truck, which will tell you how to operate safely and maintain preventively. Relevant operator and maintainer must read this manual before operation.

Because of the update and improvements of our products, there may be some differences between this operation manual contents and your forklift truck.

Please contact the sales company or agent of Hangcha Group in case of anything unclear.

This series of forklifts have passed CE certification.

| Model | Traction motor controller | Pump motor controller | Traction motor | Pump motor | Rated capacity (t) / Load center (mm) |
|----------------|---------------------------|-------------------------|-------------------------|-------------------------|---------------------------------------|
| CPD20-XCY2-SI | AILPY352-7 20002-000 | AILPY352-7 20002-000 | XCIPY300-130000- 000 | XCIPY300-611000-0 00 | 2.0/ 500 |
| CPD25-XCY2-SI | AILPY352-7 20002-000 | AILPY352-7 20002-000 | XCIPY300-130000- 000 | XCIPY300-611000-0 00 | 2.5/ 500 |
| CPD30-XCY2-SI | XEIPY301-7 21030-000 | AILPY352-7 20002-000 | XCIPY300-130000- 000 | XCIPY300-611000-0 00 | 3.0/ 500 |
| CPD35-XCY2-SI | XEIPY301-7 21030-000 | AILPY352-7 20002-000 | XCIPY300-130000- 000 | XCIPY300-611000-0 00 | 3.5/ 500 |
| CPD38-XCY2-SI | XEIPY301-7 21030-000 | AILPY352-7 20002-000 | XCIPY301-130000- 000 | XCIPY301-611000-0 00 | 3.8/ 500 |
| CPD20-XCY2H-SI | XEIPY301-7 21030-000 | AILPY352-7 20002-000 | XCIPY301-130000- 000 | XCIPY301-611000-0 00 | 2.0/ 500 |
| CPD25-XCY2H-SI | XEIPY301-7 21030-000 | AILPY352-7 20002-000 | XCIPY301-130000- 000 | XCIPY301-611000-0 00 | 2.5/ 500 |
| CPD27-XCY2H-SI | XEIPY301-7 21030-000 | AILPY352-7 20002-000 | XCIPY301-130000- 000 | XCIPY301-611000-0 00 | 2.7/ 500 |

| Model | Traction motor controller | Pump motor controller | Traction motor | Pump motor | Rated capacity (t) / Load center (mm) |
|----------------|---------------------------|-------------------------|-------------------------|-------------------------|---------------------------------------|
| CPD30-XCY2H-SI | XCIPY301-7 21020-000 | XEIPY301-7 21030-000 | XCIPY301-130000- 000 | XCIPY301-611000-0 00 | 3.0/ 500 |
| CPD35-XCY2H-SI | XCIPY301-7 21020-000 | XEIPY301-7 21030-000 | XCIPY301-130000- 000 | XCIPY301-611000-0 00 | 3.5/ 500 |
| CPD15-XCY2-SI | AILPY352-7 20002-000 | AILPY352-7 20002-000 | XCIPY150-130000- 000 | XCIPY150-611000-0 00 | 1.5/ 500 |
| CPD18-XCY2-SI | AILPY352-7 20002-000 | AILPY352-7 20002-000 | XCIPY150-130000- 000 | XCIPY150-611000-0 00 | 1.8/ 500 |
| CPD20-XCXY2-SI | AILPY352-7 20002-000 | AILPY352-7 20002-000 | XCIPY150-130000- 000 | XCIPY150-611000-0 00 | 2.0/ 500 |



Warning

In order to ensure the combination of the charging gun plug and the lithium battery socket, and prevent the lithium battery gun from loosening during the charging process, the lithium battery gun is provided with a lock, which cannot be pulled out even if it is pulled hard. So after charging, the lock must be released. Only by pressing the button on the charging gun can the lock be released and the charging gun can be pulled out smoothly.

To smoothly pull out the lithium battery charging gun, press the button on the gun. Or the gun and socket will be damaged.

Content

| | |
|---|-----------|
| 1 TRUCK INTRODUCTION | 1 |
| 1.1 SUMMARY | 1 |
| 1.2 USE OCCASIONS AND CONDITIONS | 2 |
| 1.3 APPEARANCE AND MAIN PART | 3 |
| 1.4 DISPLAYS AND CONTROLS | 4 |
| 1.5 LITHIUM BATTERY CHARGING PORT STRUCTURE AND ITS SIDE DOOR | 18 |
| 1.6 LITHIUM BATTERY REPLACEMENT AND INSTALLATION | 18 |
| 1.7 TRUCK BODY AND OTHERS | 20 |
| 1.8 ADJUST AND REPLACE FORKS | 25 |
| 1.9 OPERATOR PRESENCE SENSING | 27 |
| 1.10 MAIN TECHNICAL PERFORMANCE PARAMETER TABLE | 29 |
| 1.11 NAMEPLATE AND WARNING LABEL | 35 |
| 1.12 STRUCTURE AND STABILITY OF TRUCK | 37 |
| 2 SAFETY INSTRUCTIONS | 41 |
| 3 OPERATION AND SAFETY PRECAUTIONS FOR THE ELECTRIC FORKLIFT LITHIUM BATTERY | 48 |
| 4 TRUCK LIFTING, CARRYING AND TOWING | 52 |
| 4.1 LIFTING | 52 |
| 4.2 CARRYING | 53 |
| 4.3 TOWING | 54 |
| 5 LITHIUM BATTERY | 55 |
| 5.1 SAFETY NOTICE | 55 |
| 5.2 INSTALLATION INSTRUCTIONS | 55 |
| 5.3 BASIC TERMS OF LITHIUM-ION POWER BATTERY | 56 |
| 5.4 USAGE NOTICE | 56 |
| 5.5 DAILY MAINTENANCE | 57 |
| 5.6 EMERGENCY PLAN | 57 |
| 5.7 DIMENSION/ WEIGHT | 58 |
| 5.8 CHARGING OF LITHIUM BATTERIES | 59 |
| COMMON FAULTS AND SOLUTIONS OF BATTERIES | 68 |
| 6 OPERATING INSTRUCTIONS | 71 |
| 6.1 DURING RUNNING-IN | 71 |
| 6.2 CHECK AND ADJUST BEFORE OPERATION | 72 |
| 6.3 OPERATION | 78 |

| | | |
|----------|---|------------|
| 7 | MAINTENANCE | 82 |
| 7.1 | MAINTENANCE SUMMARY | 82 |
| 7.2 | REGULAR MAINTENANCE SCHEDULE | 84 |
| 7.3 | REPLACE THE KEY SAFE PARTS TERMLY | 94 |
| 7.4 | FORKLIFT USED OIL AND LUBRICATION | 95 |
| 7.5 | REPLACE WHEEL | 98 |
| 7.6 | 电器盒 | 101 |
| 7.7 | INSPECTION AND REPAIR OF CONTROL SYSTEM ASSEMBLY | 102 |
| 7.8 | BOLT TIGHTENING TORQUE TABLE | 105 |
| 8 | THE USE, INSTALL AND SAFETY RULES OF ATTACHMENT | 106 |
| 8.1 | ATTACHMENT INSTALL | 106 |
| 8.2 | ATTACHMENT USE | 106 |
| 8.3 | ATTACHMENT CHECK AND MAINTENANCE | 107 |
| 9 | RELATED SAFETY INSTRUCTION AND STANDARD (FOR TRUCKS EXPORTING TO EUROPE OR OPTION) | 108 |

1 Truck introduction

1.1 Summary

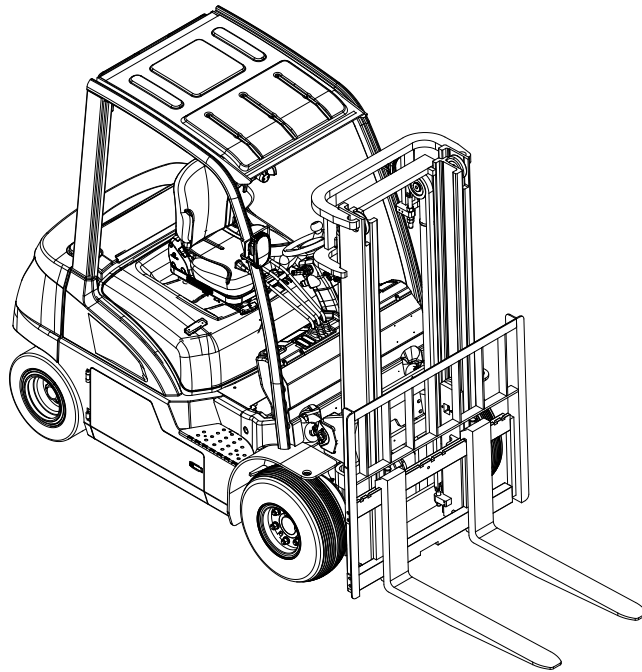

Truck body

- Lateral battery extraction frame. The lithium battery sinks to the bottom of the frame.

Drive and brake system

- Integrated drive axle
- High-efficiency and high-power AC drive motor provides super driving force, and the driving speed can reach 17km/h.

Control system

- Ergonomic, large operating space

Hydraulic system

- Adopted high-power oil pump motor and working oil pump greatly improves the lifting speed.

Electrical system

- 80V battery pack provides super power. Lithium battery adopts Ningde Era battery cell.
- Large-size color screen instrument, standard cloud intelligent management module.
- 采用永磁电机和永磁控制器

Steering system

Angle sensor

The driving speed is about 17km/h, the lifting speed is about 460mm/s, and the performance is in

line with the X series internal combustion vehicles of the same tonnage.

1.2 Use occasions and conditions

The forklifts described in this manual are only suitable for loading and unloading and transporting goods over short distances.

It must be used, operated and maintained according to the information in this manual. Any other uses are outside the design envelope and can lead to injury to persons or damage to equipment or property.

Only used in specified place and condition:

- Use in specified rated load.
- Used in specified area as factory, tourist attraction and recreation place.
- Used on the flat ground, that is fixed and owns enough carrying capacity.
- Used on the road with good vision and equipment use license.
- Approved working site temperature is $-5^{\circ}\text{C} \sim 40^{\circ}\text{C}$.
- Altitude should not over 2000m.
- Max. gradability when driving with full load is 18%. It is prohibited to travel crosswise or obliquely when going uphill. When going uphill with loads, keep the loads in front; when going downhill, keep people in front.

Please read other safety rules in this manual, it is important to your personal safety, working staff and goods safety.



Warning

- It is forbidden to drive outside the designated areas such as highways.
- Overloading and illegally carrying people are strictly prohibited.
- Do not push or pull loads.
- Non-explosion-proof forklifts are forbidden to be used in flammable and explosive places.
- If it is not a cold storage type, it is forbidden to use it in a cold storage.

1.3 Appearance and main part

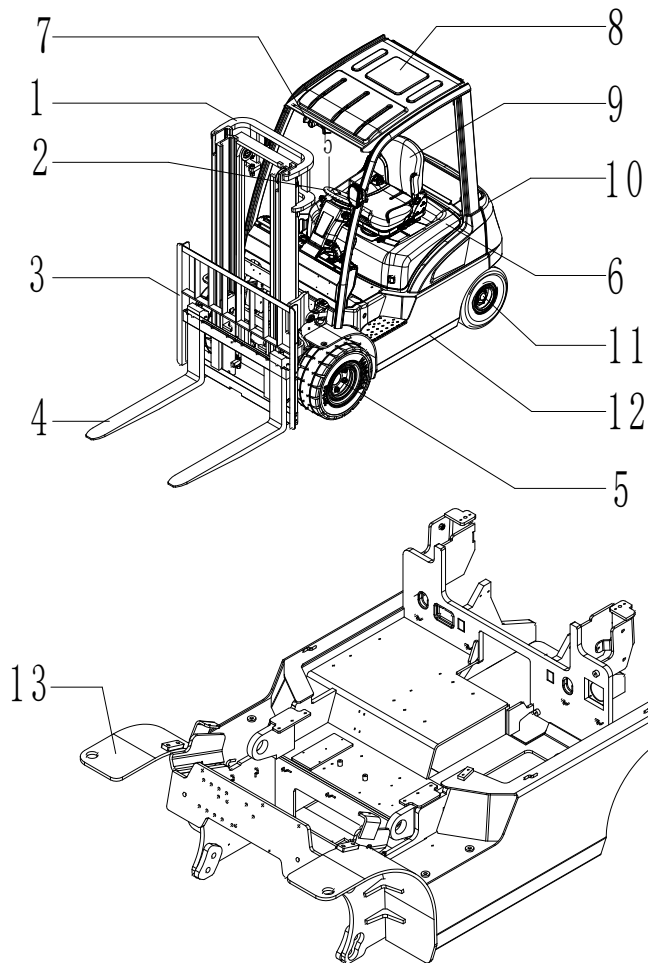

| 编号 | 名称 | 编号 | 名称 |
|----|-----------------|----|-----------------------------------|
| 1 | Mast | 8 | Overhead guard |
| 2 | Steering wheel | 9 | Seat |
| 3 | Load bracket | 10 | Counterbalance weight |
| 4 | Forks | 11 | Steering axle |
| 5 | Drive axle | 12 | Frame |
| 6 | cover | 13 | Printing position of frame number |
| 7 | Rearview mirror | | |

1.4 Displays and controls

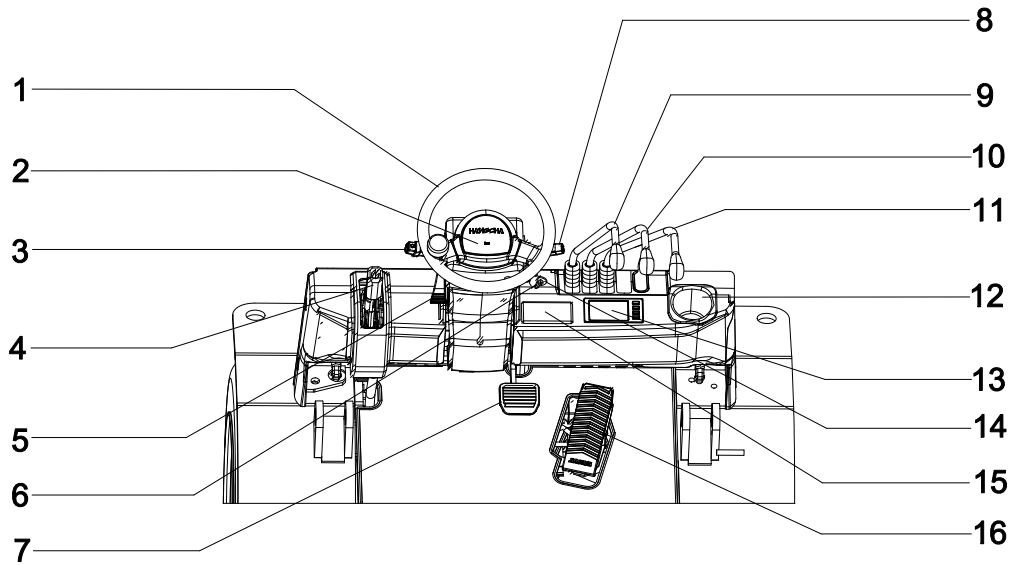

| | | | |
|--------------------|-----------------------------|---------------------|--------------------------------|
| 1、Steering wheel | 5、Steering wheel tilt lever | 9、Lifting lever | 13、meter |
| 2、Horn button | 6、Key switch | 10、Tilting lever | 14、Emergency disconnect switch |
| 3、Reversing lever | 7、Brake pedal | 11、Sideshift lever | 15、Rocker switch |
| 4、Hand brake lever | 8、Combination switch | 12、Water cup holder | 16、Accelerator pedal |

Steering wheel [1]

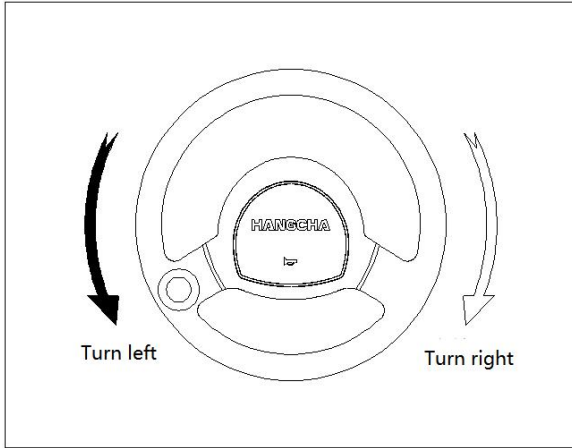

Control the truck direction.

When the steering wheel is turned right, the forklift will turn to the right; when the steering wheel is turned left, the forklift will turn to the left. The rear end of the forklift swings out when turning.

Warning

This forklift truck adopts a fully hydraulic steering system. Therefore, steering will be impaired when the oil pump motor stops running. Immediately restart the oil pump motor before turning again.

Horn button [2]

Press the horn button in the center of the steering wheel and the horn will sound.

Reversing lever [3]

It is installed on the left of the steering column.

| | |
|---|---------|
| F | Forward |
| N | Neutral |
| R | Reverse |

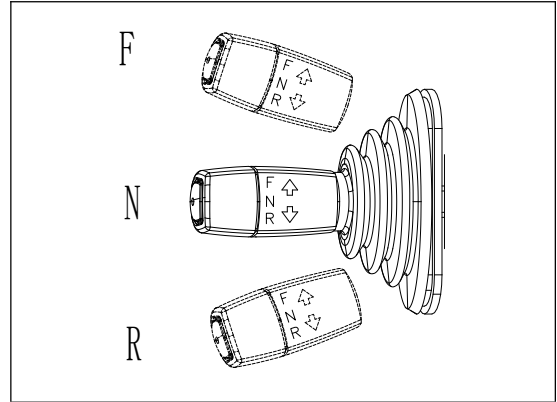

Before changing the direction of travel, depress the brake pedal to bring the vehicle to a complete stop, then shift the handle forward to a forward gear. If you need to go backwards, depress the brake pedal to slow down the speed of the vehicle, move the handle backwards to a reverse gear.

Caution

The forklift can only be started when the lever is in the neutral position.

Hand brake lever [4]

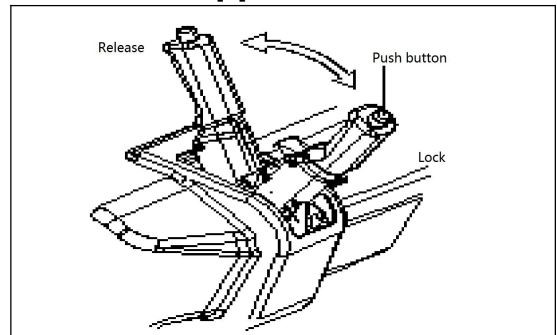

Pull the handle back to tighten it; push the handle forward to loosen it. The handle must be pulled tight before the operator leaves the forklift.

Caution

In case of brake system doesn't work or emergency occurs, you can tighten this

lever to stop the truck urgently. Usually, it is strictly forbidden to use the handbrake to achieve service braking.

Steering wheel tilt lever[5]

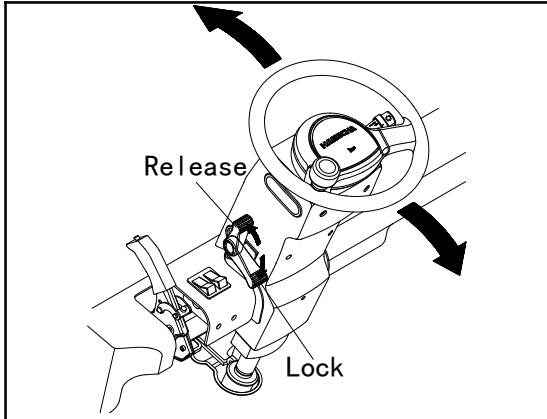

Position of steering wheel is adjustable. Pull up the lever on the left side of direction column, and adjust the steel wheel to the desired position, and then push down the lever to lock.

! Caution

- Only after stopping the truck and pulling up the hand brake lever can you adjust the tilting angle of steering wheel.
- After adjustment, turn the steering wheel up and down firmly to make sure it is locked.

Key switch [6]

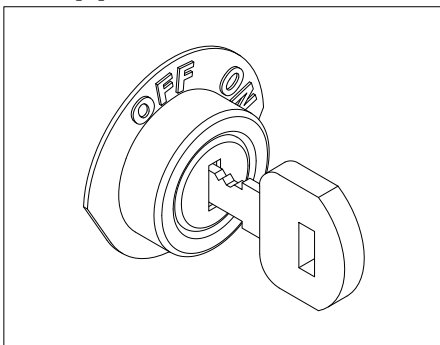

Switch on and off the control current. Remove the key and make sure that the truck does not move suddenly.

The key switch has two positions: ON and OFF. First set the direction lever to the neutral position, release the accelerator pedal, and then turn the key clockwise to the ON position.

! Caution

- If the direction lever is not in neutral or the accelerator pedal is depressed, the forklift will not start when the key switch is turned to ON.
- At this point a fault code will be displayed, which is perfectly normal.
- Return the direction lever to the neutral position and take your foot off the accelerator pedal before attempting to start the forklift.
- The fault code will then disappear.

Brake pedal [7]

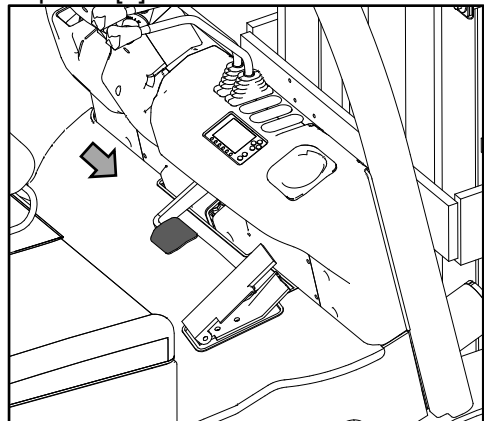

Depressing the brake pedal will slow down or stop the forklift. Release the pedal and the vehicle runs.



Caution

Avoid sudden braking. Sudden braking can easily cause the vehicle to overturn or the cargo to fall, resulting in a safety accident.

Combination lights [8]

The combination lights include turn signal lights and light switch.

Turn signal: Push or pull this switch, the corresponding left and right turn signal light flash.

| | | |
|--------------|--|--------------------------|
| Push Forward | | Left turn light flashes |
| Neutral | | Off |
| Pull back | | Right turn light flashes |



Caution

Steering lamp switch can not return to neutral position automatically, and should reset manually.

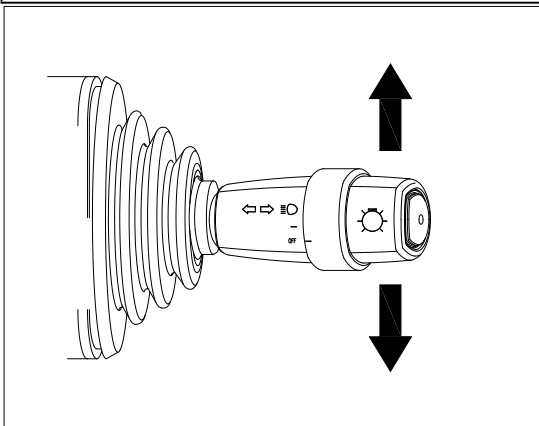

Light switch: Rotation type switch. Control

the light through the knob on the head of combination switch.

×: Indicates that it is connected

| Contact symbol | Light symbol | Front lamp | Head lamp | Width lamp |
|----------------|--------------|------------|-----------|------------|
| — | | | × | × |
| | — | × | | × |
| | OFF | | | |

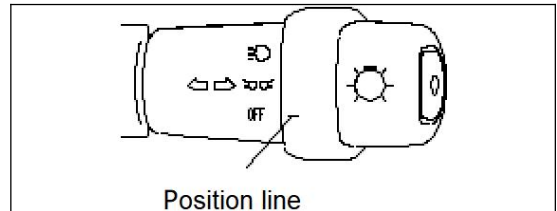

To turn on the headlights, front signal lights, and width lamps, turn the switch to align the position line on the switch handle with the corresponding mark on the switch body.

Lift lever [9]

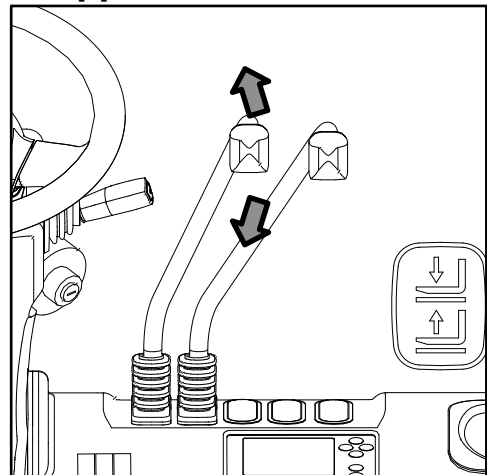

Control the forks' up or down.
Push—down; pull—up

Lifting speed can be controlled by tilt backwards angle of lever and accelerator pedal, the lowering speed can be controlled by tilt forwards angle of the lever.

Tilt lever [10]

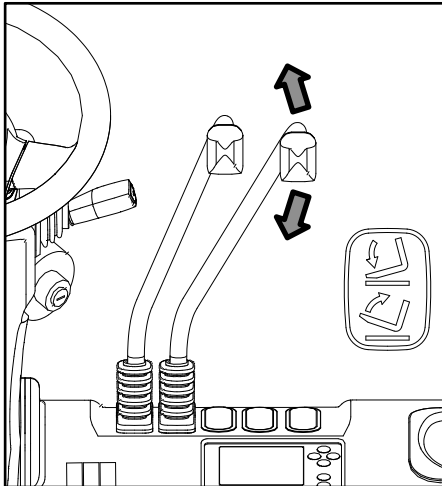

It is used for forward and backward tilting of the mast.

Push—tilt forward;

Pull—tilt backward

The tilting speed is controlled by tilting angle of the lever and accelerator pedal effort.

! Caution

The multi-way valve is equipped with a front tilt self-locking valve. When the circuit is cut off, the mast cannot tilt forward even if the lever is pushed forward.

Side shifter lever[11] (According to the requirements of accessories)

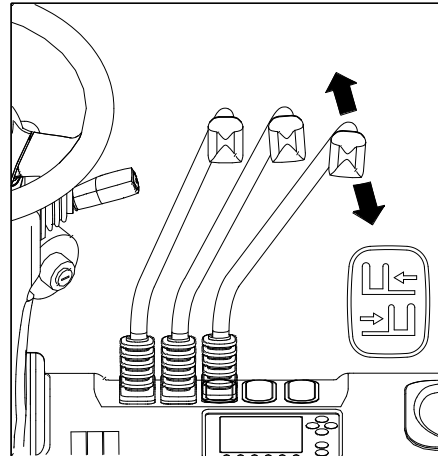

It's used for left shift and right shift of sideshifter bracket

Push—Left shift Pull—Right shift

The side shifting speed is controlled by the tilt angle of the lever and accelerator control.

Attachment lever

It can be a sideshift control lever, or a rotary control lever or other attachment control lever, depending on the specific situation.

Cup holder [12]

It is in the right side of the instrument stand for driver placing the cup.

Emergency stop button [14]

Turn the power on or off.

In case of emergency, press the red mushroom button to cut off the main power of the vehicle. No walking, turning, lifting.

! Caution

Do not use the emergency stop switch to stop the truck under normal circumstances as the key switch.

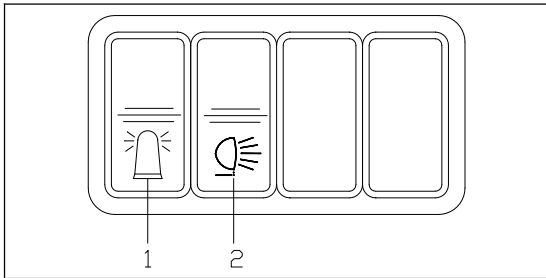

Rocker switch [15] [optional]



The rocker switch is the warning light and the rear headlight, the left is the warning light and the right is the rear headlight.

1 Alarm light switch: press down, the alarm light flashes; press up, the alarm light goes out.

2 Rear headlight switch: press down, the rear headlight is on; press up, the rear headlight is off.

| Symbol | Control element |
|---|-----------------|
|  | Warning Light |
|  | Rear headlight |

Caution

Whether this light is on or off has nothing to do with the position of the key switch, so do not forget to turn off the light.

Accelerator pedal [16]

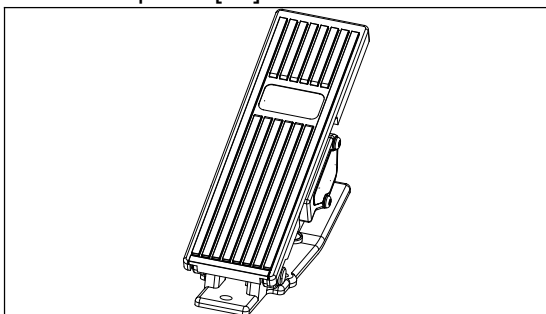

Stepless regulation for the driving speed of the forklift.

Slowly depress the accelerator pedal, the drive motor will start running and the forklift will move off. According to the pedaling force on the pedal, the running speed can be adjusted steplessly.

Caution

Release the accelerator pedal while driving to perform soft braking.

Warning

Do not depress the accelerator pedal before turning on the key switch, otherwise the meter will display a fault. Release the accelerator pedal, the fault will disappear.

Headlights

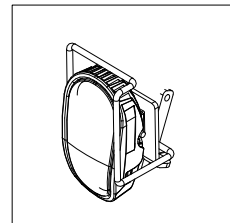

When the lighting conditions of the working environment do not meet the requirements, it is required to turn on the headlights

Fingertip operation (option)

Armrest system is composed of armrest bracket, fingertip, emergency stop button, horn button and wire etc.

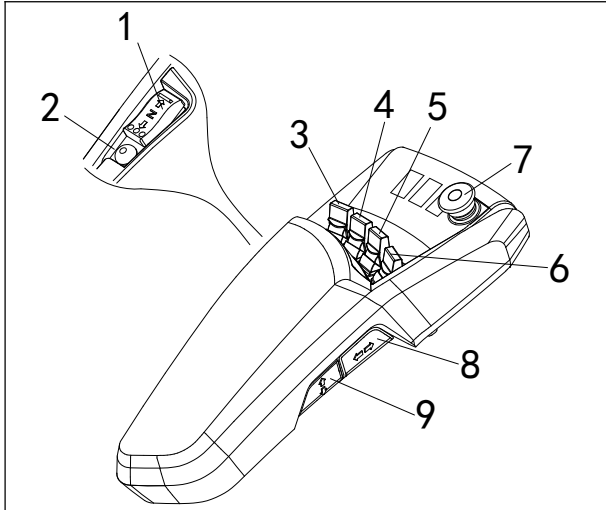

| | | |
|--------------------------|-----------------------|--------------------------|
| 1. Direction switch | 2. Horn button | 3. Lift switch |
| 4. Tilt switch | 5. Sideshift switch | 6. Attachment switch |
| 7. Emergency stop button | 8. Level shift handle | 9. Vertical shift handle |

Direction switch

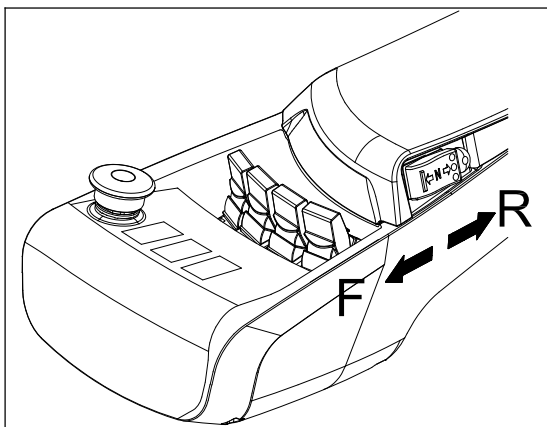

Set forklift direction according to need.

Direction switch is used to switch the forklift going forward or backward. Press the switch forward and step on the accelerator pedal, forklift travels forward; press the switch backward, forklift travels back.



- If press the direction switch to opposite direction during truck running, the electric braking works to decelerate the forklift. After stop, the truck moves to another direction.
- If the direction lever is not in neutral, when the key switch is turned on, a fault code will be displayed. Return the direction lever to the neutral position, the fault code will then disappear.

Lift switch

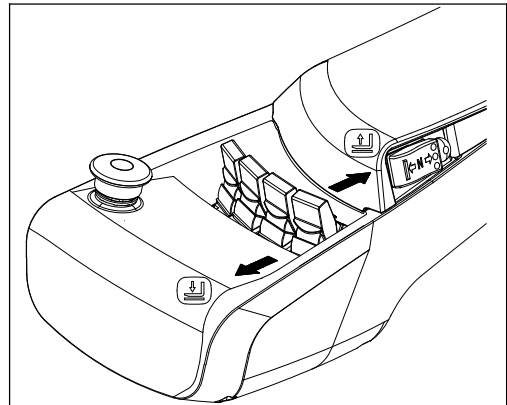

Push the switch forward to lower the fork; pull the switch backward to lift the fork. The lifting and lowering speed is controlled by the tilt angle of the switch, the larger the angle, the faster the speed.

Tilt switch

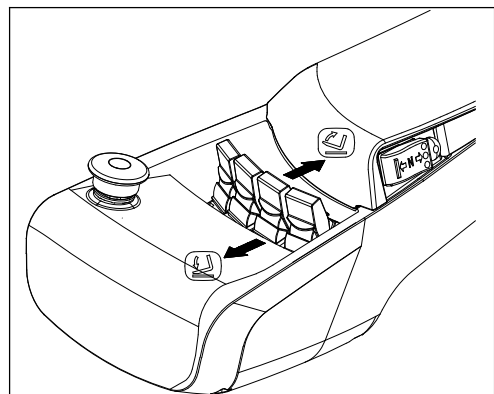

Push the switch forward to tilt the fork forward; pull the switch backward to tilt the fork backward; The tilting speed is controlled by the tilt angle of the switch.



Caution

- The multi-way valve is equipped with a front tilt self-locking valve. When the circuit is cut off, the mast cannot tilt forward even if the lever is pushed forward.

Sideshift switch

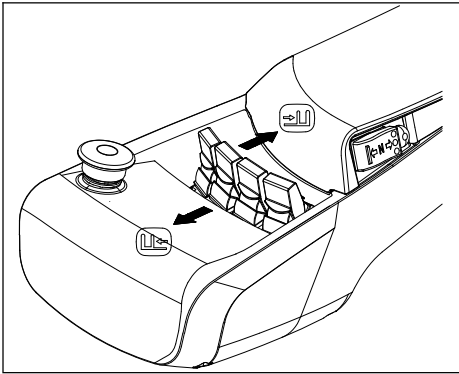

Move the switch back and forth to make the fork move left and right relative to the mast.

Attachment switch

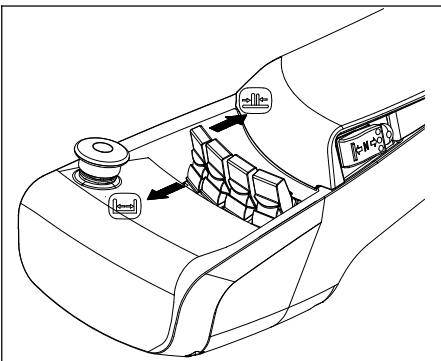

Apply when installing the attachment with the fourth valve. Push and pull this switch can realise the attachment function.

Horn button

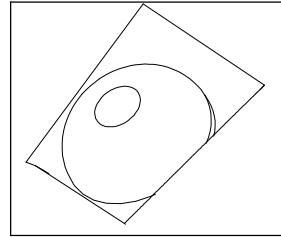

Press this button when a reminder or warning audible signal is required.

Emergency stop button

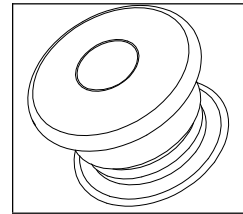

In an emergency, press the button to cut off the vehicle's main power supply.



Caution

- Do not use the emergency stop switch to stop the truck under normal circumstances as the key switch.

Level shift handle 松开 loosen 锁紧 locking

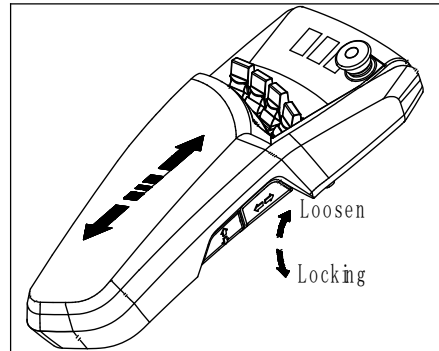

Adjust horizontal position of armrest : Turn upward, release the armrest and move it to proper position; turn downward, lock the armrest.

Vertical shift handle

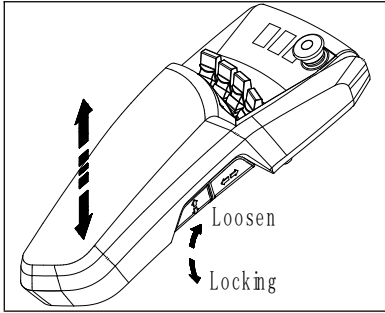

Adjust armrest height: Turn upward, release the armrest and vertically move it to proper position; turn downward, lock the armrest.

Meter [13]

1. Instrument function introduction

XC series forklift intelligent instrument is a kind of on-board color screen instrument based on CAN bus, which can display vehicle speed, battery power, working hours, accumulated mileage, Chinese and English display, password protection, fault code, driver and lithium battery monitoring information, etc. At the same time, users can change driver parameters through the instrument to meet personal customization requirements.

2. Display of instrument main interface

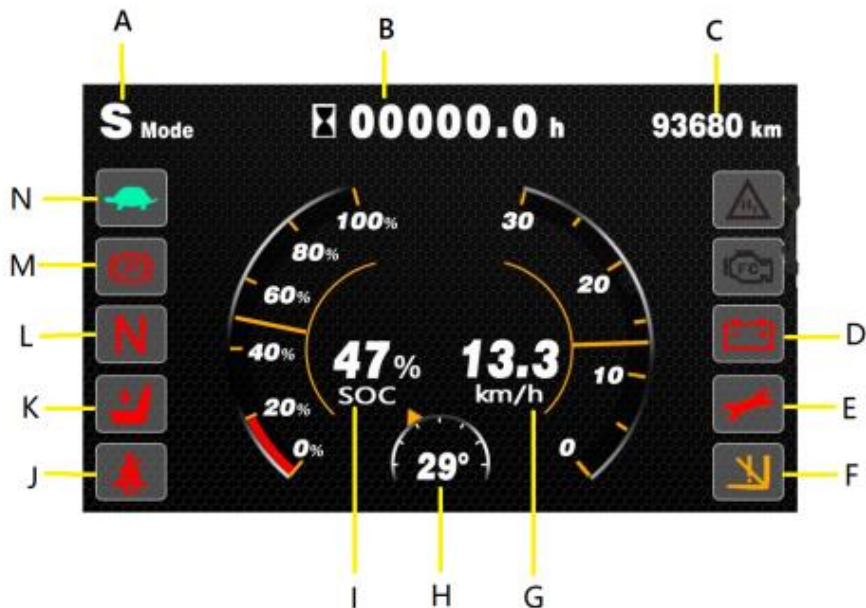

| | | |
|--------------------------|-------------------------|--------------------|
| A. Operating mode | H. Steering angle | B. Operating hours |
| I. Power display | C. Odometer | J. Power display |
| D. Low battery display | K. Seat switch | E. Fault indicator |
| L. Neutral indicator | F. Working device limit | M. Stop indicator |
| G. Vehicle speed display | N. Tortoise speed mode | |

Operating mode[A]

There are four operation modes: S mode, P mode and E mode (tortoise speed mode)

S mode: fast mode. At this time, the acceleration and maximum gradient of the forklift are high. It is suitable for carrying heavy goods or climbing slopes in a short time. The power consumption is the highest in this mode.



P mode: normal mode, with various indicators slightly lower than fast mode, which is applicable to the general operating environment. This mode is the default mode.

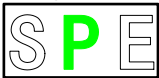

E mode: Tortoise speed mode, where the maximum speed is limited, is suitable for working in crowded warehouses and narrow spaces.



Operating hours[B]

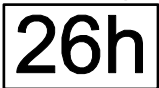

When the forklift key switch is turned on, the operation of the forklift starts timing. When the forklift key switch is turned off, the operation of the forklift stops timing.

Low battery display[D]



When the battery power is lower than 20%, this indicator is always on; When the battery level is higher than 20%, this indicator will go out.

Fault indicator light[E]



This indicator is always on when the electrical system fails. After troubleshooting, this indicator light goes out.

Working device limit indicator[F]



When the power is only 10%, the light will be on, and the lifting speed of the mast will be reduced to remind the user to charge the battery as soon as possible.

Vehicle speed display[G]

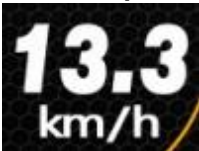

The measuring range is 0~30km/h, and it is displayed with a decimal point.

Steering angle[H]



The left and right steering angles of the vehicle are displayed in °

Power display [I]



Display the remaining capacity of the battery, the display range is 0~100%, and the accuracy is 1. It is recommended to charge the battery when the remaining power is 30%, otherwise the service life of the battery will be greatly shortened.



Caution

- It is important to charge the battery in time, otherwise the service life of the battery will be affected!

Safety belt[J]



Fasten the safety belt. This indicator will light up when the safety belt is not fastened.

Seat switch[K]

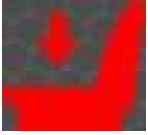

When people leave the seat, this light will be on, indicating that the seat switch is off, and the vehicle cannot walk and lift at this time. This function requires the installation of seats with seat switches

Neutral indicator light[L]



When the gear is in neutral, this indicator light will be on.

Stop indicator light [M]



When the hand brake is pulled up, this indicator light is on.

Tortoise speed mode[N]



This indicator is on when the vehicle is running in slow mode (E mode).

3. Instrument keys

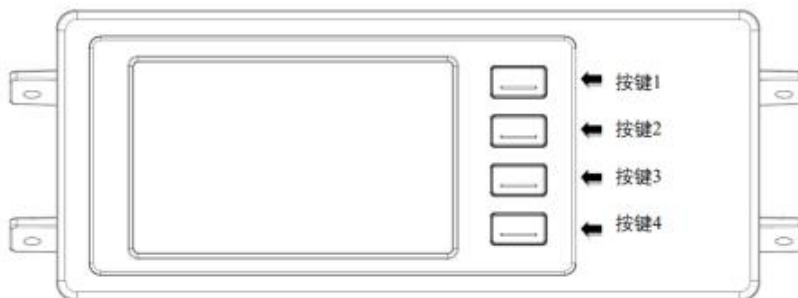

(1) In the main interface, click button 1 to view the fault information, click button 1 and button 2 to page up and down to view multiple fault information, and click button 4 to return to the main interface.

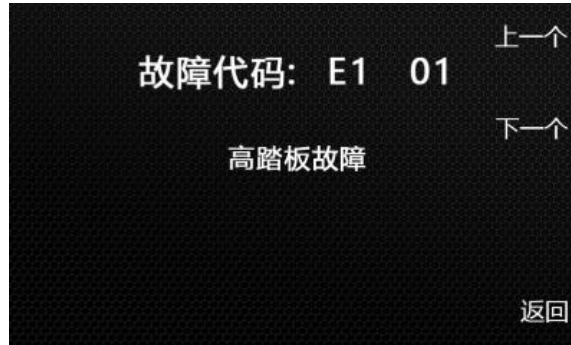

(2) In the main interface, press key 2 to switch between the three operation modes: fast mode S, normal mode P, and tortoise speed mode E. The mode indicator icon will change accordingly.



(3) Under the main interface, click button 3 to view the monitoring information, click button 1 and button 2 to turn pages up and down to view the monitoring information of traction controller, slave traction controller (reserved), oil pump controller, slave oil pump controller (reserved) and lithium battery, and click button 4 to return to the main interface.

(4) Under the main interface, press key 4 to enter the setting page, press key 1 and key 2 to switch to different sub page options, press key 3 to enter the selected sub page, and press key 4 again to return to the main interface.

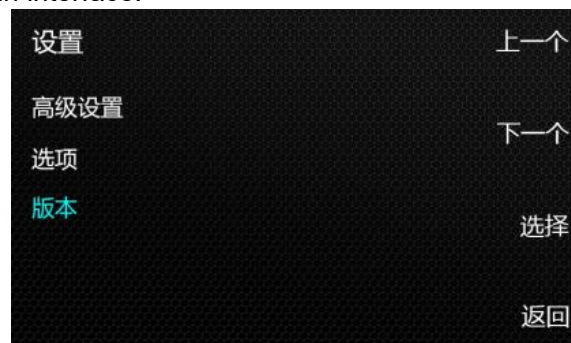

4.Options Page

(1) Language Settings

Press key 1 and key 2 to select Chinese and English options; Press key 3 to confirm, the interface

will automatically jump to the previous interface and the language will change accordingly; Press key 4 to cancel the setting and return to the previous interface.

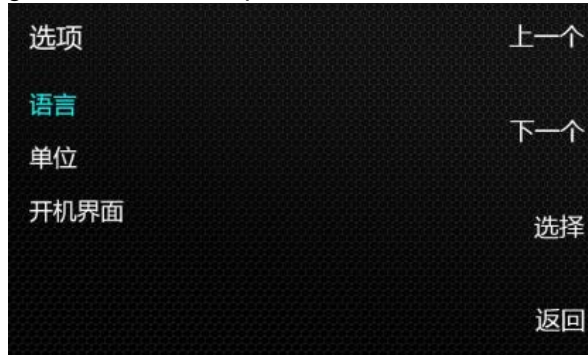

(2) Unit Setting

Press key 1 and key 2 to select English system and metric system options; Press key 3 to confirm, the interface will automatically jump to the previous interface, and the main interface unit will change accordingly; Press key 4 to cancel the setting and return to the previous interface.



(3) Startup interface settings

Press key 1 and key 2 to select Hang Fork Logo and No Boot Screen; Press key 3 to confirm, the interface will automatically jump to the previous interface, and the boot interface will change accordingly; Press key 4 to cancel the settings and return to the previous interface.



1.5 Lithium battery charging port structure and its side door

The charging port of the lithium battery and its side door are introduced separately here. Because the side door and charging port are often used when charging.

For details of lithium batteries and chargers, see the introduction section below.

Lithium battery charging port structure and its side door



Move the charging port to the right rear of the truck body, and the charging door assembly adopts magnet attraction, which is very convenient to open and charge.



Note: The flat side of the plug is equipped with a locking hook that snaps into the slot when inserted into the battery socket.

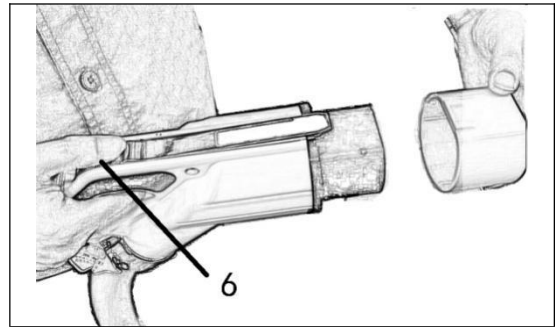

To insert or pull out, press the lock button (6) on the charging gun head.

Fastening of lithium battery:

The right side of the lithium battery clamps the frame through the battery clamping device to achieve the purpose of fastening. The clamping device is equipped with two bolts, and the heads of the bolts are welded with washers. When tightening the bolts clockwise, install the lithium battery firmly in the horizontal direction.

1.6 Lithium battery replacement and installation

The lithium battery sinks at the bottom of the vehicle body, and the side is fastened by a protective rod. Rely on the weight to sit on the frame. For the removal and installation of

lithium batteries.

a. Loosen the plug(1) of the lithium battery and the truck body, open the side door (2), loosen the bolt (3) on the fastening device, and lift it up a short distance (4), and then take it out, the lithium battery can be taken out from the body

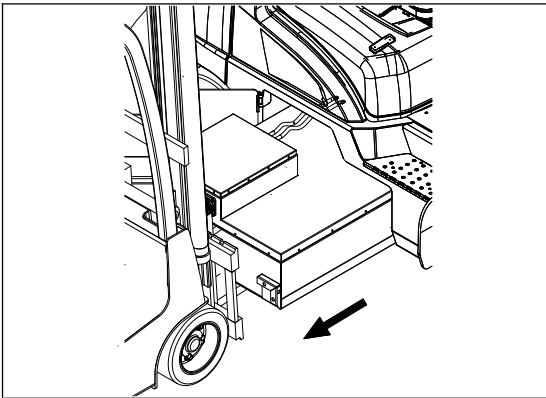
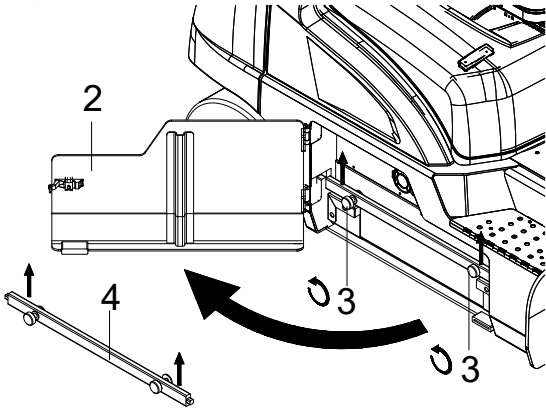

b. Center the fork to the middle of the two rows of rollers, take out the battery, and transfer it to the fork.

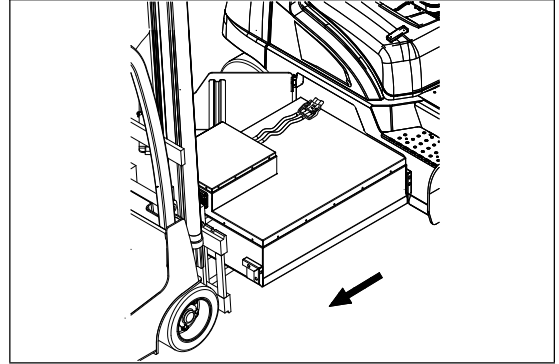

c. Lift 1cm with a forklift or pallet truck, pay attention to adjusting the fork spacing, and gently pull out the lithium battery.

Install

Installation is the opposite of removal.



Warning

Carefully hoist, the lithium battery weighs about 320kg, which is very heavy
During installation, prevent crushing feet or clamping hands.



Caution

The service weight of the replacement battery should be within the min/max range specified on the manufacturer's vehicle nameplate.

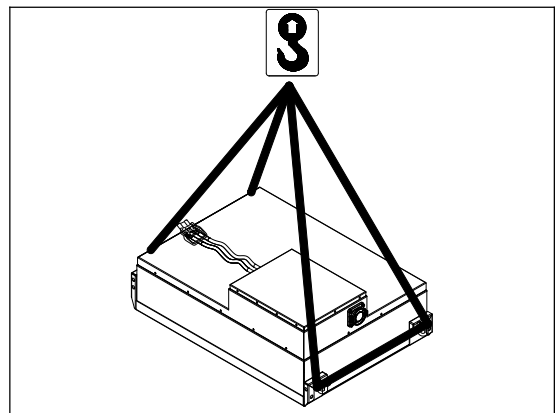

Lift the lithium battery to the ground with a lifting device, and the fixing points are shown in the figure above.

1.7 Truck body and others

Load bracket

Load bracket can guarantee the stable goods loading. It's forbidden to use the forklift without the load bracket. It is forbidden to disassemble and modify the load bracket

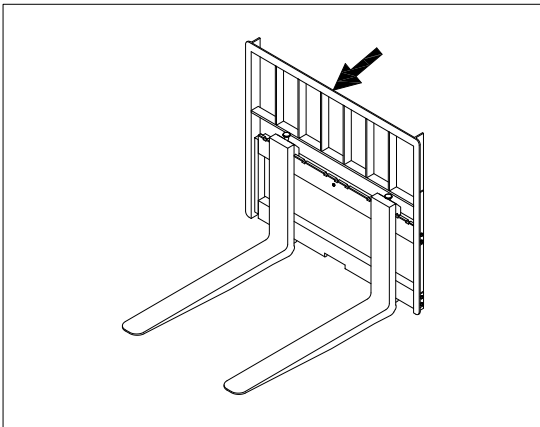

Seat

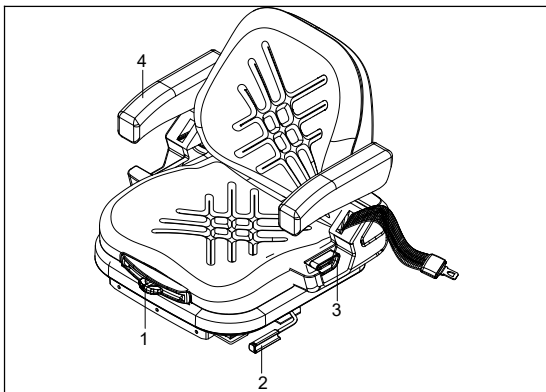

- 1: Weight adjustment lever
- 2: Forward and rearward adjustment lever
- 3: Backrest angle adjustment lever
- 4: Armrest adjustment knob

·Seat weight adjustment

Pull up the weight adjustment lever and then move the lever to left or right side horizontally

to adjust the seat to the driver's weight where it's comfortable for driving and working.

·Forward and rearward adjustment of the seat
Move the lever to inner side with hands, and then move the seat assembly forward or rearward to adjust the seat to a proper position. When the handle is released, the seat will be locked automatically.

·Backrest angle adjustment

When seated on a seat, lay the back on the seat backrest and pull the backrest angle adjustment lever upward with left hand. Do not release the lever until a proper position is fitted to the seat by moving the body forward or backward.

·Armrest adjustment

The inclination angle of the armrest can be adjusted by turning the adjustment knob. When the knob is turned outward, the front of the armrest will lift. When the knob is turned inward, the front of the armrest will lower.



Warning

- Turn off the key before adjusting the seat.
- It's prohibited to adjust the position of the seat only when the truck stops.
- In case of accident, no seat adjustment is allowed in the process of travelling.
- Make sure the lever is moved completely to separate the seat structure before the forward and rearward adjustment of the seat and angle adjustment of seat backrest.
- After adjustment, each lever should be back in place. Before using the truck, make sure the lock of every part is reliable.

Seat belt

·Fasten the belt

Belt was huddled up in the box. There is a secondary action to draw out the belt. So you

may meet some trouble due to not be familiar with it.

One kind of seat: it needs to press the white circular button (with the words: press to release) by one hand, then the belt can be pulled out by the other hand and inserted into the socket.

You may also meet another seat: the belt box is adjustable. Rotate the belt box forward, the belt can not be drawn out. Rotate the belt box backward, the belt is drawn out. Insert the belt into the socket of the other side. Rotate the belt box forward again and then the belt is in normal working position.

Please fasten the belt when get on the truck. Meanwhile, get the back and waist close to the seat. Don't tie the seat in the abdomen.

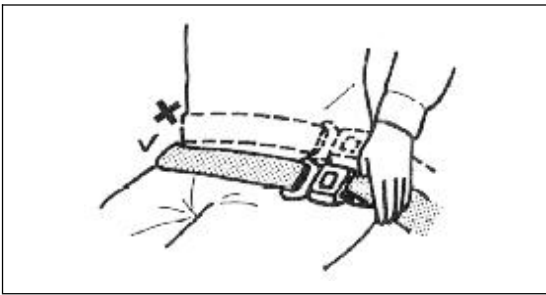

Please don't have the seat backrest tilted excessively. Otherwise, the belt can not be extended correctly.

Do not use knotted or twisted straps.

To tie the belt in the daily operation will protect you when the truck turns over and reduce the harm.

·Unfasten the belt

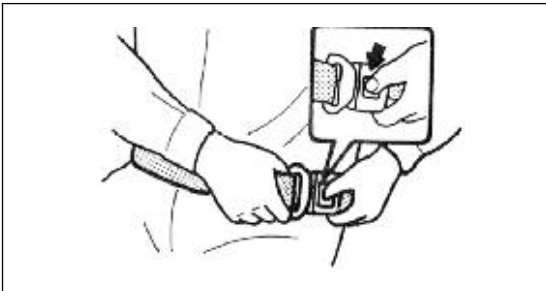

Press the red button (with the word PRESS) in the socket with left pollex, it's unfastened.

·Check the belt

Check if the bolt that fixed belt is loosened. Don't press the belt on the hard or frangible objects and prevent from grinding with the sharp blade to avoid damage.

It is prohibited to remove any parts of the belt. The belt used frequently needs to be checked frequently.

- Cutting or cracking;
- Worn or damaged metal parts, including anchor points;
- Failure of belt buckle or traction device;
- Loose thread.

If abnormal condition occurs, please change a new belt immediately. The service life of the belt is three years, so reject it in advance if it's abnormal.

Overhead guard

The overhead guard protects the operator from being damaged by falling materials. It must have enough shock resistance strength. It's not allowed to use forklift without overhead guard. The overhead guard should be tightened frequently.

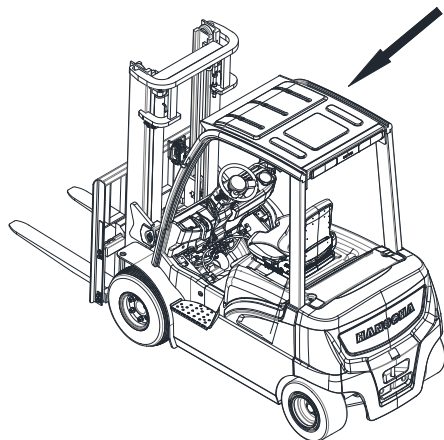

Lock components

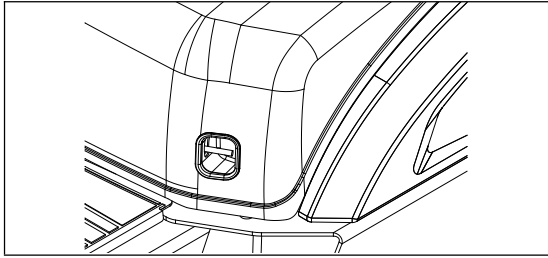

To avoid opening the hood arbitrarily, a lock assembly is set here. To open the hood, you must first pull the handle of the lock assembly. And then the cover is released.

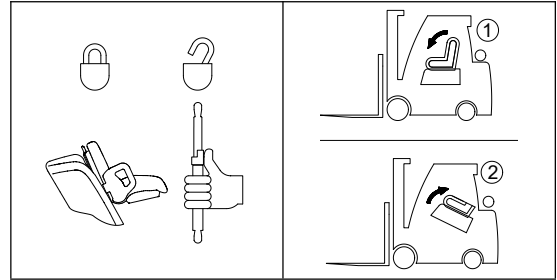

When closing, press the red button on the gas spring cylinder, at this time the lock is released, press the head of the hood to close, and after hearing a "click" sound, it means that the hood is locked.

Air spring

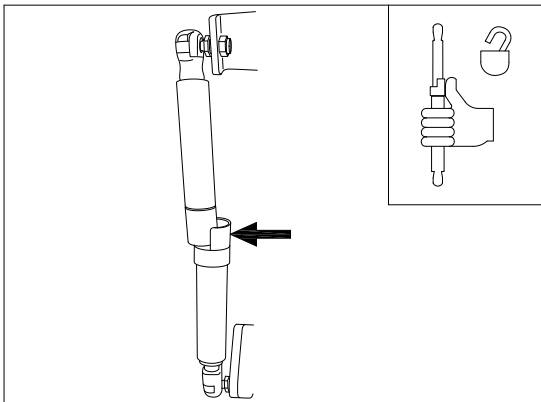

When opening the cover, it is used to support the cover. When closing the cover, press down the cover firmly while pressing the red button in the direction of the arrow shown in the figure.

Cover

The wide-opening cover facilitates battery maintenance. The gas spring inside the cover enables the cover to be fully opened upwards with very little force.

Caution
Prevent the cover from clamping your finger when closing the cover.

Warning
When performing maintenance under the cover, be sure to turn off the key switch to prevent electric shock. However, when the hands, feet, head, and body do not touch the components, in order to diagnose the fault by hearing, it is allowed to open the key switch and open the cover at this time.

Fork locating pin

Fork locating pins are used for adjusting the fork space. Pull up it, turn 180° and shift the forks to the desired position.

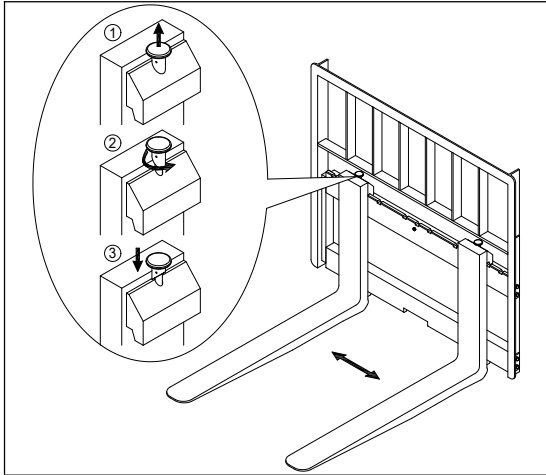

Warning

The forks should be set symmetrically to machine centerline and fork stoppers should always be locked.

The lower beams of the fork carriage have an opening section to load or unload forks.

Do not set the forks over the opening. Check the bolt at the middle of the fork carriage used to prevent fork load at the opening.

Pedal and handrail for getting on and off the truck

There equips with pedals for getting on and off the truck on both side of the truck, and handrail on left leg of overhead guard. Always face the forklift when getting on and off. Please use the handrail for safety.

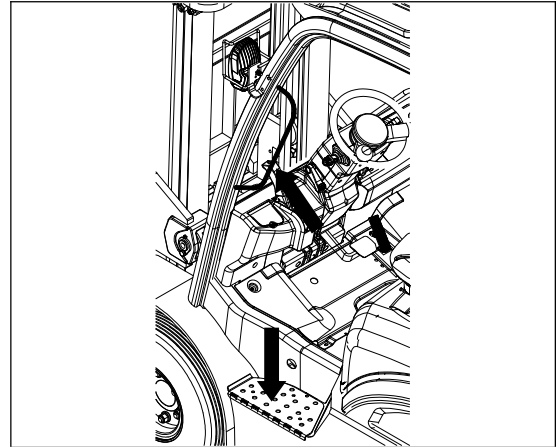

Hydraulic fluid reservoir cap

The hydraulic fluid reservoir cap is located on the left frame inside the cover. Open the cover when adding oil. Fill clean hydraulic oil through this oil filler. After filling, lock the cap.

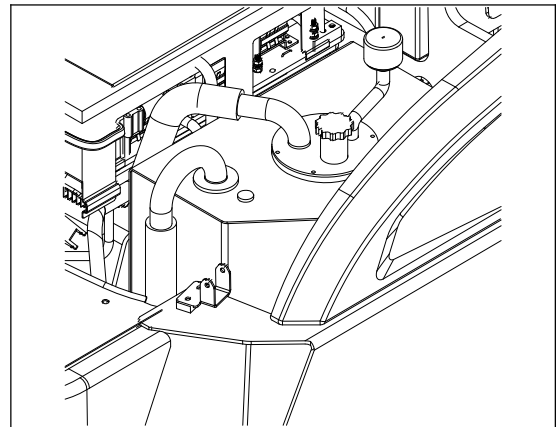

Rearview mirror

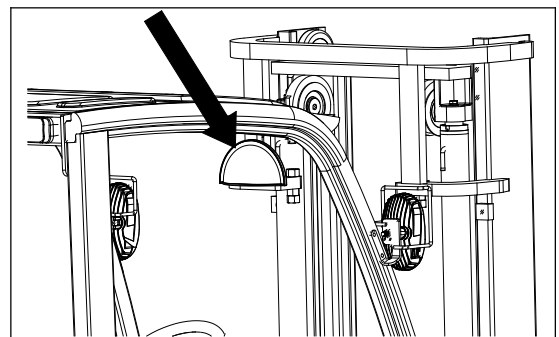

A circular arc rearview mirror is installed on the upper right of overhead safeguard, and is for the use of observing rear condition or back

up.

Brake fluid reservoir

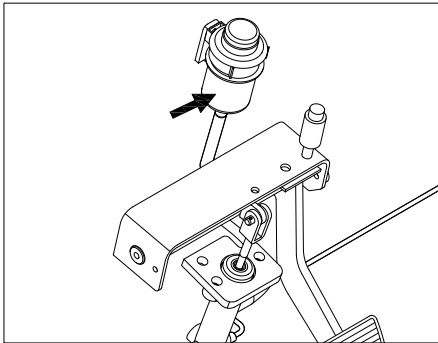

The brake oil cup is installed in the instrument frame directly under the steering wheel. The translucent can allows us to check the brake fluid level from the outside.



Caution

When filling the brake fluid, prevent dust and debris from entering the oil cup. Brake fluid is corrosive and toxic.

Socket plug

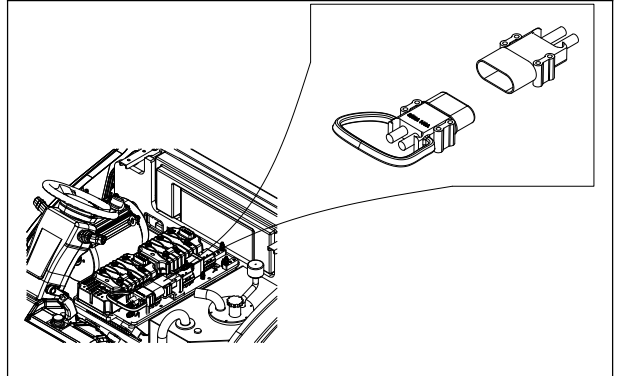

1.8 Adjust and replace forks

Adjust fork distance

In order to guarantee safe operation of picking loads, before operation, adjust the fork distance to proper position according to the tray dimension.

Steps:

- Pull up the fork locating pin upward, and rotate 180° in random direction, then fork is unlocked.
- Based on fork carriage center line, adjust the fork position to both ends symmetrically.
- After adjusting the fork distance, pull up the fork locating pin upward, rotate to original position, and then slide the forks left or right a little to make sure the fork locating pin get in the slot of fork carriage.

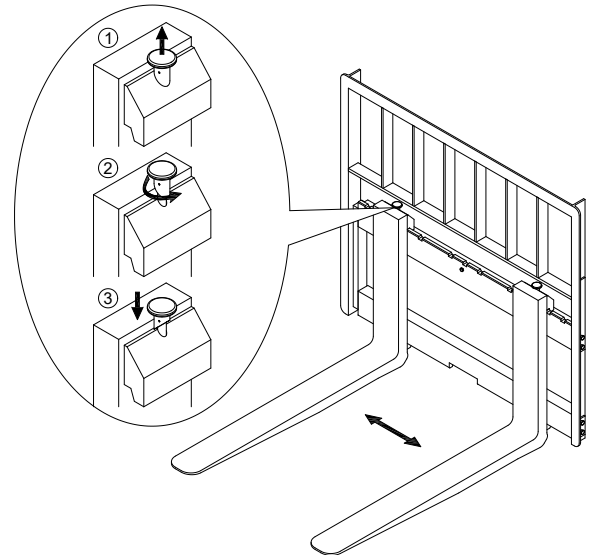

Fork distance is adjusted.



Caution

- **Fork locating pin must be locked (keep in the slot of fork carriage), otherwise forks are easy to move during driving and loads may fall down.**
- **Be careful when adjusting forks.**

Fork removal



Caution

- **There is an opening on the lower beam of the fork carriage to assemble and disassemble forks.**
- **It's prohibited to fix forks on the fork carriage opening, prevent forks dropping from the opening.**
- **There installs a bolt in the middle of upper beam to prevent forks working here. Replace in time if bolt is damaged.**

Fork disassemble:

When replacing forks, screw off the fixed bolt in the middle of the fork carriage, move the fork to

the middle opening of fork carriage beam, and then tilt forward and lower the forks until forks are off the fork carriage, then back the truck.



Fork assemble:

Place forks on the ground against the truck, lower the fork carriage to the lowest, drive the truck forward slowly, aim at the upper and lower slot of fork and the upper and lower beam and gap of fork carriage, fully lift the fork carriage, adjust the left and right position of forks and lock it.



1.9 Operator Presence Sensing

OPS (Operator Presence Sensing) system is a safeguard system that installs a sensor in the driver seat to sense if the driver sits on the seat correctly. If the driver does not sit on the seat correctly, driving force is cut off, meanwhile, all loading and unloading operations will be stopped. It helps to reduce accident when the driver leaves. When the driver does not sit correctly, the driver cannot drive the truck or operate the loading and unloading, thereby reduce safety accidents caused by misoperation.



Driving protection function

When the vehicle is travelling, the driver leaves the seat or the safety belt is released (if equip with safety belt protection switch) over 1 second, truck stops automatically, and the instrument displayed seat indicator light  lights up, meanwhile the buzzer sends out continuous alarm signal. Only when pulling up the hand brake or the driver sits on the seat correctly and the direction switch returns to neutral, the seat indicator light  goes out, travelling OPS status is released.

Working protection function

When the vehicle is under working condition, the driver leaves the seat or the safety belt is released (if equip with safety belt protection switch) over 1 second, working stops automatically, and the instrument displayed seat indicator light  lights up, meanwhile the buzzer sends out continuous alarm signal. OPS light comes on, buzzer sends out alarm signal, transportation operation stops automatically. When the driver sits down again, the seat indicator light  goes out, working OPS status is released.



Warning function

Once the seat sensor detects the seat switch is turned off, within 1 second, the buzzer sends out continuous alarm signal, and the seat indicator light  lights up. If the seat indicator light  keeps on when the seat switch is off, it means the OPS in the startup state.

Resume neutral function

If the direction switch does not return to neutral and the seat switch is turned on. The buzzer will send out continuous alarm signal to remind the driver that the OPS in the startup state.

OPS abnormal function handling

Park the truck in safe place and contact Hangcha agency to check if any below condition is occurred. a. after the driver leaves the seat, the seat indicator light  does not light up; b. when the driver sits down, the seat indicator light  does not go out.

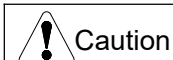

As to forklift equipped with safety belt protection switch, driver needs to sit on the seat correctly and also needs fasten safety belt, and then operate the truck. When driving on the uphill, starting the OPS will cut off the drive power and make the truck slip. In order to avoid this accident, the driver must sit correctly when operating on the uphill.

Fork locking function after power off

This function means: forks are locked when starting switch is on or off, forks will not lower down even operate the control lever.

1.10 Main technical performance parameter table

The technical data given below are standard data. Our company reserves the right to make technical changes and supplements

| No. | Item | | unit | CPD20-XCY2-SI | CPD25-XCY2-SI |
|-----|-----------------------------|---------------------------|------|-----------------|-----------------|
| 1 | Rated load capacity | | kg | 2000 | 2500 |
| 2 | Load center distance | | mm | 500 | 500 |
| 3 | Service weight | Including lithium battery | kg | 3640 | 3980 |
| 4 | Mast Lifting height | maximum | mm | 3000 | 3000 |
| | | Free lift height | mm | 140 | 140 |
| 5 | Mast max. tilting angle | F/R | ° | 6/12 | 6/12 |
| 6 | Dimension | Length(to fork face) | mm | 2290 | 2290 |
| | | Width | mm | 1252 | 1252 |
| | | Height | mm | 2100 | 2100 |
| 7 | Min. outside turning radius | | mm | 2035 | 2035 |
| 8 | Battery | Brand | | CATL | CATL |
| | | Voltage/Capacity | V/Ah | 80/202 | 80/202 |
| | | Weight | kg | 200 | 200 |
| 9 | Motor | Drive | kW | 16 | 16 |
| | | Pump | kW | 23 | 23 |
| 10 | Tires | Front tire/number | | 23×9-10-18PRR/2 | 23×9-10-18PRR/2 |
| | | Rear tire/number | | 18×7-8-16PRR/2 | 18×7-8-16PRR/2 |
| 11 | Max. travelling speed | Laded/Unladen | km/h | 16/17 | 16/17 |
| 12 | Max. lifting speed | Laded/Unladen | mm/s | 350/460 | 350/460 |
| 13 | Maximum drawbar pull | Laded (3km/h) | kN | 11 | 12 |
| 14 | Braking length | Laded | m | ≤4 | ≤4 |

| No. | Item | | unit | CPD30-XCY2-SI | CPD35-XCY2-SI |
|-----|-----------------------------|---------------------------|------|------------------|------------------|
| 1 | Rated load capacity | | kg | 3000 | 3500 |
| 2 | Load center distance | | mm | 500 | 500 |
| 3 | Service weight | Including lithium battery | kg | 4620 | 5100 |
| 4 | Mast Lifting height | maximum | mm | 3000 | 3000 |
| | | Free lift height | mm | 145 | 150 |
| 5 | Mast max. tilting angle | F/R | ° | 6/12 | 6/12 |
| 6 | Dimension | Length(to fork face) | mm | 2460 | 2475 |
| | | Width | mm | 1298 | 1298 |
| | | Height | mm | 2100 | 2167 |
| 7 | Min. outside turning radius | | mm | 2180 | 2180 |
| 8 | Battery | Brand | | CATL | CATL |
| | | Voltage/Capacity | V/Ah | 80/302 | 80/302 |
| | | Weight | kg | 230 | 230 |
| 9 | Motor | Drive | kW | 13 | 13 |
| | | Pump | kW | 18 | 18 |
| 10 | Tires | Front tire/number | | 23×10-12-18PRR/2 | 23×10-12-18PRR/2 |
| | | Rear tire/number | | 18×7-8-16PRR/2 | 18×7-8-16PRR/2 |
| 11 | Max. travelling speed | Laded/Unladen | km/h | 16/17 | 16/17 |
| 12 | Max. lifting speed | Laded/Unladen | mm/s | 350/460 | 350/460 |
| 13 | Maximum drawbar pull | Laded (3km/h) | kN | 14 | 13 |
| 14 | Braking length | Laded | m | ≤4 | ≤4 |

| No. | Item | | unit | CPD20-XCY2H-SI | CPD25-XCY2H-SI |
|-----|-----------------------------|---------------------------|------|-----------------|-----------------|
| 1 | Rated load capacity | | kg | 2000 | 2500 |
| 2 | Load center distance | | mm | 500 | 500 |
| 3 | Service weight | Including lithium battery | kg | 3620 | 3980 |
| 4 | Mast Lifting height | maximum | mm | 3000 | 3000 |
| | | Free lift height | mm | 140 | 140 |
| 5 | Mast max. tilting angle | F/R | ° | 6/12 | 6/12 |
| 6 | Dimension | Length(to fork face) | mm | 2290 | 2290 |
| | | Width | mm | 1252 | 1252 |
| | | Height | mm | 2100 | 2100 |
| 7 | Min. outside turning radius | | mm | 2035 | 2035 |
| 8 | Battery | Brand | | CATL | CATL |
| | | Voltage/Capacity | V/Ah | 80/271 | 80/271 |
| | | Weight | kg | 230 | 230 |
| 9 | Motor | Drive | kW | 20 | 20 |
| | | Pump | kW | 26 | 26 |
| 10 | Tires | Front tire/number | | 23×9-10-18PRR/2 | 23×9-10-18PRR/2 |
| | | Rear tire/number | | 18×7-8-16PRR/2 | 18×7-8-16PRR/2 |
| 11 | Max. travelling speed | Laded/Unladen | km/h | 19/20 | 19/20 |
| 12 | Max. lifting speed | Laded/Unladen | mm/s | 500/600 | 500/600 |
| 13 | Maximum drawbar pull | Laded (3km/h) | kN | 16 | 18 |
| 14 | Braking length | Laded | m | ≤4.5 | ≤4.5 |

| No. | Item | | unit | CPD30-XCY2H-SI | CPD35-XCY2H-SI |
|-----|-----------------------------|---------------------------|------|------------------|------------------|
| 1 | Rated load capacity | | kg | 3000 | 3500 |
| 2 | Load center distance | | mm | 500 | 500 |
| 3 | Service weight | Including lithium battery | kg | 4620 | 5100 |
| 4 | Mast Lifting height | maximum | mm | 3000 | 3000 |
| | | Free lift height | mm | 145 | 150 |
| 5 | Mast max. tilting angle | F/R | ° | 6/12 | 6/12 |
| 6 | Dimension | Length(to fork face) | mm | 2460 | 2475 |
| | | Width | mm | 1298 | 1298 |
| | | Height | mm | 2100 | 2167 |
| 7 | Min. outside turning radius | | mm | 2180 | 2180 |
| 8 | Battery | Brand | | CATL | CATL |
| | | Voltage/Capacity | V/Ah | 80/456 | 80/456 |
| | | Weight | kg | 320 | 320 |
| 9 | Motor | Drive | kW | 16 | 16 |
| | | Pump | kW | 21 | 21 |
| 10 | Tires | Front tire/number | | 23×10-12-18PRR/2 | 23×10-12-18PRR/2 |
| | | Rear tire/number | | 18×7-8-16PRR/2 | 18×7-8-16PRR/2 |
| 11 | Max. travelling speed | Laded/Unladen | km/h | 19/20 | 19/20 |
| 12 | Max. lifting speed | Laded/Unladen | mm/s | 450/550 | 450/550 |
| 13 | Maximum drawbar pull | Laded (3km/h) | kN | 21 | 22 |
| 14 | Braking length | Laded | m | ≤4.5 | ≤4.5 |

| No. | Item | | unit | CPD38-XCY2-SI | CPD27-XCY2H-SI |
|-----|-----------------------------|---------------------------|------|----------------|------------------|
| 1 | Rated load capacity | | kg | 3800 | 2700 |
| 2 | Load center distance | | mm | 500 | 500 |
| 3 | Service weight | Including lithium battery | kg | 5260 | 4100 |
| 4 | Mast Lifting height | maximum | mm | 3000 | 3000 |
| | | Free lift height | mm | 150 | 150 |
| 5 | Mast max. tilting angle | F/R | ° | 6/12 | 6/12 |
| 6 | Dimension | Length(to fork face) | mm | 2525 | 2378 |
| | | Width | mm | 1298 | 1252 |
| | | Height | mm | 2100 | 2100 |
| 7 | Min. outside turning radius | | mm | 2210 | 2050 |
| 8 | Battery | Brand | | CATL | CATL |
| | | Voltage/Capacity | V/Ah | 80/456 | 80/302 |
| | | Weight | kg | 320 | 270 |
| 9 | Motor | Drive | kW | 20 | 120 |
| | | Pump | kW | 28 | 26 |
| 10 | Tires | Front tire/number | | 23×10-12(K2)/2 | 23×10-12-18PRR/2 |
| | | Rear tire/number | | 200/50-10/2 | 18×7-8-16PRR/2 |
| 11 | Max. travelling speed | Laded/Unladen | km/h | 19/20 | 19/20 |
| 12 | Max. lifting speed | Laded/Unladen | mm/s | 450/550 | 430/600 |
| 13 | Maximum drawbar pull | Laded (3km/h) | kN | 13 | 18 |
| 14 | Braking length | Laded | m | ≤4 | ≤4.5 |

| No. | Item | | unit | CPD15-XCY2-SI | CPD18-XCY2-SI | CPD20-XCXY2-SI |
|-----|-----------------------------|---------------------------|------|---------------|---------------|----------------|
| 1 | Rated load capacity | | kg | 1500 | 1800 | 2000 |
| 2 | Load center distance | | mm | 500 | 500 | 500 |
| 3 | Service weight | Including lithium battery | kg | 2850 | 3080 | 3240 |
| 4 | Mast Lifting height | maximum | mm | 3000 | 3000 | 3000 |
| | | Free lift height | mm | 147 | 147 | 140 |
| 5 | Mast max. tilting angle | F/R | ° | 6/12 | 6/12 | 6/12 |
| 6 | Dimension | Length(to fork face) | mm | 2095 | 2100 | 2156 |
| | | Width | mm | 1120 | 1120 | 1138 |
| | | Height | mm | 2080 | 2080 | 2080 |
| 7 | Min. outside turning radius | | mm | 1910 | 1910 | 1935 |
| 8 | Battery | Brand | | CATL | CATL | CATL |
| | | Voltage/Capacity | V/Ah | 80/173 | 80/173 | 80/173 |
| | | Weight | kg | 120 | 120 | 120 |
| 9 | Motor | Drive | kW | 10 | 10 | 10 |
| | | Pump | kW | 18 | 18 | 18 |
| 10 | Tires | Front tire/number | | 6.00-9-10PR/2 | 6.00-9-10PR/2 | 21×8-9-16PR/2 |
| | | Rear tire/number | | 16×6-8-10PR/2 | 16×6-8-10PR/2 | 16×6-8-16PR/2 |
| 11 | Max. travelling speed | Laded/Unladen | km/h | 16/17 | 16/17 | 16/17 |
| 12 | Max. lifting speed | Laded/Unladen | mm/s | 380/500 | 380/500 | 330/500 |
| 13 | Maximum drawbar pull | Laded (3km/h) | kN | 8 | 9 | 9 |
| 14 | Braking length | Laded | m | ≤4.5 | ≤4.5 | ≤4.5 |

1.11 Nameplate and warning label

Labels and warning label, like nameplate, load curve and warning label, must be clear and readable. Replace when necessary.

The following picture displays the rough position of each label. Before operation, please study the meaning of each symbol.

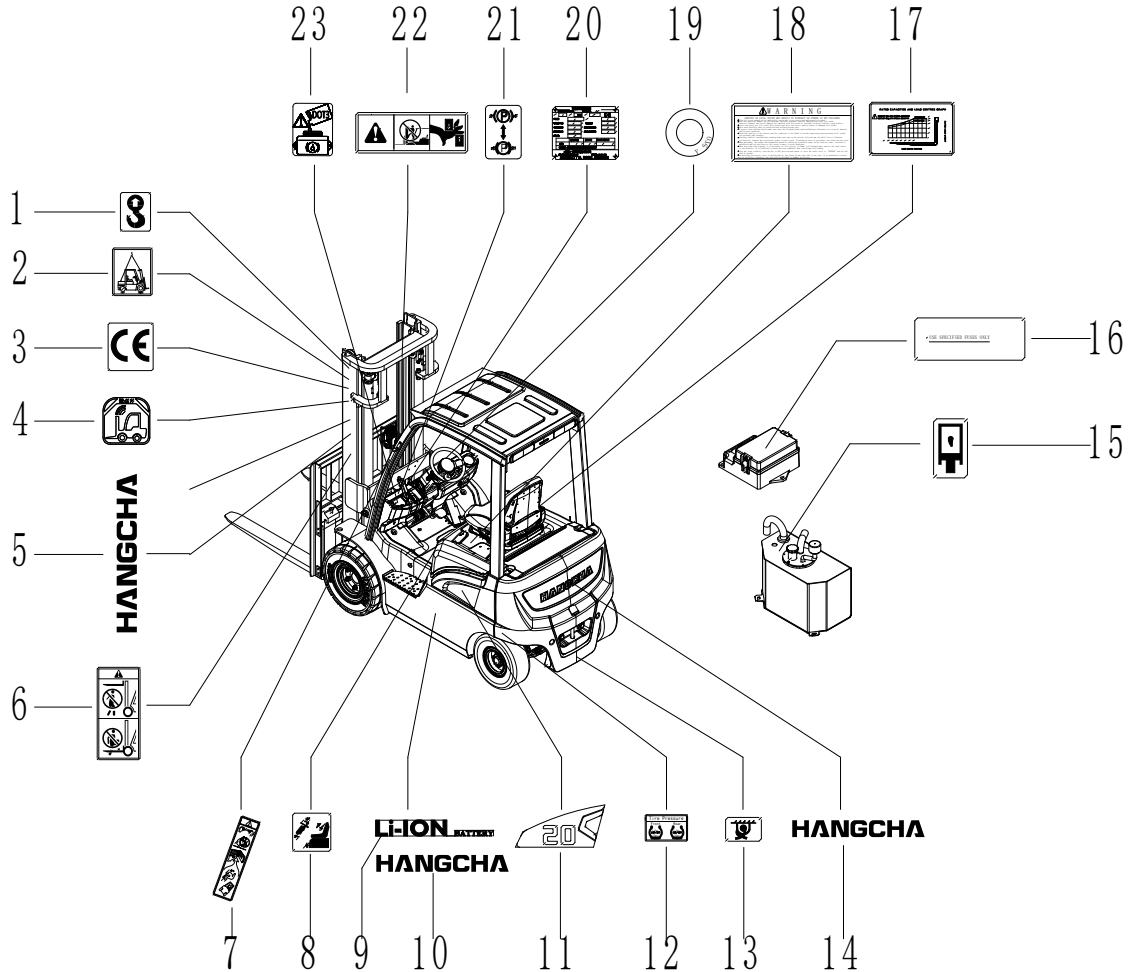

| No. | Description |
|-----|---|
| 1 | Lifting point label: The fixed point of the equipment when loading and unloading by crane |
| 2 | Lifting method label: Lifting method when loading and unloading by crane. |
| 3 | CE label (for CE vehicles) |
| 4 | Intelligent label |

| | |
|----|---|
| 5 | Manufacturer's logo |
| 6 | Danger label: It is strictly forbidden to stand on the fork, and it is strictly forbidden to stand under the fork |
| 7 | Warning labels: Measures to be taken when the forklift rolls over. |
| 8 | Open cover operation instruction label (maybe no this label) |
| 9 | Lithium battery label |
| 10 | Manufacturer's logo |
| 11 | Tonnage label |
| 12 | Tire pressure label (for pneumatic tires) |
| 13 | Tie-down point label: Tie-down point when dragging |
| 14 | Manufacturer's logo |
| 15 | Hydraulic oil filler port |
| 16 | Fuse label: Only use the specified fuse |
| 17 | Load curve label |
| 18 | Warning label |
| 19 | Emergency stop switch label |
| 20 | Product nameplate: located on the upper left of the instrument stand |
| 21 | Handbrake label |
| 22 | Danger label: Pay attention to the risk of pinching when lifting the mast. |
| 23 | Brake liquid label |

1.12 Structure and stability of truck

Prevent the forklift to turn over! It is very important for operator to know the truck's structure and relationship between load and stability.



Caution

The structure of the truck

The forklift truck essentially consists of the lifting device (forks and mast) and the truck itself (with tires).

The front wheels are the fulcrum of the forklift and keep the centre of gravity of the forklift and load balanced.

The relationship between the forklift's centre of gravity and the load's centre of gravity is very important to maintaining the operation of the forklift.

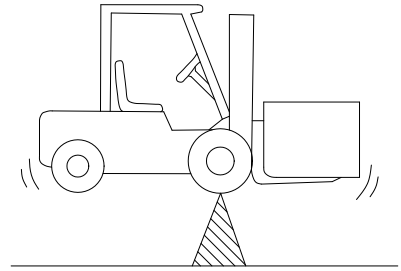

Caution

Load center

The forklift handles loads of different shapes, from crates to boards and elongated objects. In order to assess the forklift and its stability, it is very important to distinguish between the centres of gravity of different-shaped loads.

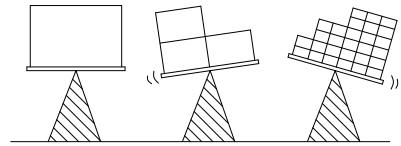

Warning

If the forklift begins to tip over, do not attempt to jump off. The truck tips over much faster than you can jump. Spread your feet and grip the steering wheel with both hands to keep yourself within the confines of the forklift.



WARNING

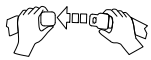

Fasten Seatbelt

IN CASE OF TIP-OVER

Follow these instructions:

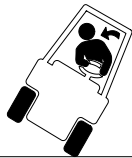

Lean Away



Hold on Tight



Brace Feet

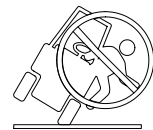

Do Not Jump



Caution

the max load and load center distance

The horizontal distance between the centre of gravity of the load on the forks and the backrest or the front face of the forks (whichever is shorter) is called the load centre distance. Maximum load is the maximum load that a forklift truck can carry at a standard load centre distance. The relationship between maximum load and load centre distance is stipulated in the forklift truck's load capacity graph. If the load centre distance moves towards the front of the forks, the overall centre of gravity shifts forward. Therefore, the load capacity decreases.

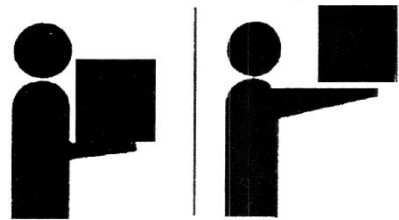

Caution

Gravity and stability

Forklift stability depends on the common centre of gravity of the forklift. When the forklift is unloaded, the centre of gravity (CoG) remains unchanged. When the forklift is loaded, the centre of gravity is formed by the combined centre of gravity of the forklift and load.

The load's centre of gravity depends on whether the mast is tilted forward or backward, raised or lowered, which means that the combined centre of gravity also changes accordingly.

The forklift's combined centre of gravity is determined by the following factors:

- Load size, weight and shape;
- Lifting height;
- Mast tilt angle;
- Tire inflation pressure;
- Acceleration, deceleration and turning radius;
- Driving surface conditions and inclination;

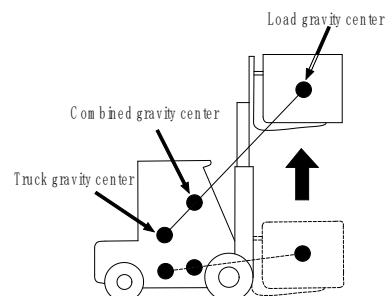
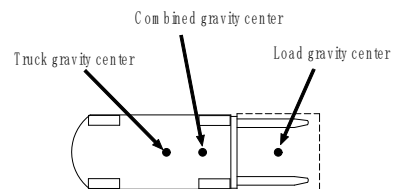

– Attachment type



Caution

the stability zone of the center of gravity

In order to stabilize the forklift, the combined centre of gravity must be located inside a triangle formed by the front wheels and the midpoint of the rear axle.

If the combined CoG is located on the front axle, the two front tires will form a fulcrum point on which the forklift will tip forward. If the combined CoG moves out of the stability triangle, the forklift will tip over in the direction that the combined CoG has moved.

Stability zone

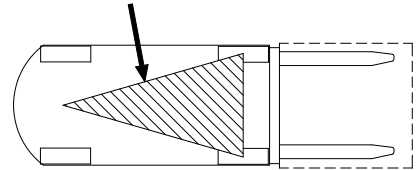

Caution

the load capability chart

This graph shows the relationship between the position of the load centre distance and the maximum load. Prior to loading, check whether the load and the load centre distance are within the limits of the load capacity graph. If a load has a complex shape, the heaviest part of the load should be centred over the forks and close to the load bracket.

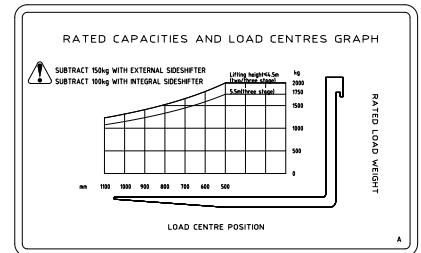



Caution

Speed and
acceleration

A stationary object will remain stationary unless an external force acts on it. Similarly, in the absence of an external force, a moving object will continue moving at the same speed. This is inertia.

Due to inertia, a rearward force is exerted when the forklift starts moving, and a forward force is exerted when the forklift stops moving.

Sudden braking is dangerous because it generates a large forward force that will cause the forklift to tip over, or the load to slide off.

When the forklift turns a corner, a centrifugal force is exerted outward from the centre of the turn. This force pushes the forklift outward and makes it tip sideways.

The truck has narrow lateral stability, so cornering must be performed slowly to prevent the forklift from tipping sideways. If the forklift is handling an elevated load, the overall centre of gravity is higher and therefore the forklift is more prone to forward or lateral tipover.

2 Safety instructions

1. Only trained and accredited operators are permitted to operate the forklift truck.

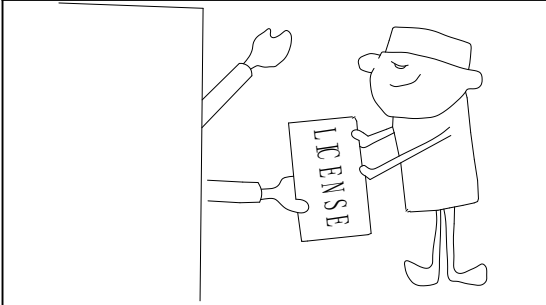

2. Operators must wear a helmet, work shoes and overalls.

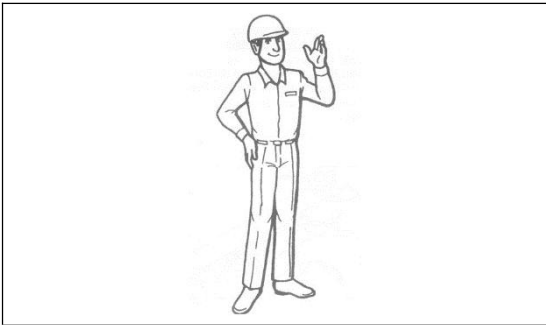

3. Never carry people.

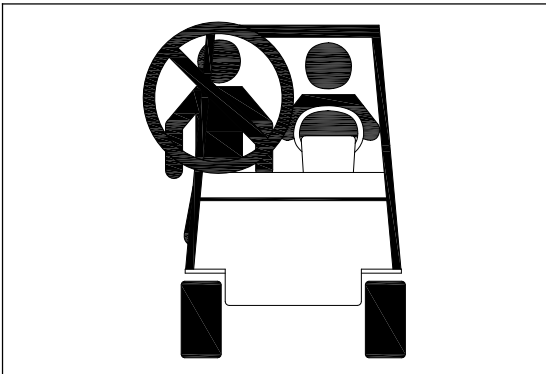

4. Inspect the truck at periodic intervals for leaks, deformation, defects, etc. Neglecting the inspection will shorten the life of the vehicle and lead to accidents in severe cases.

- Make sure to replace the "safety parts" during periodical inspection.
- Wipe off oil, grease or water from the floor

board, pedal and hand controls.

- Strictly prohibit smoking and spark near the storage battery when checking it.
 - Pay attention to safety in case of high-level maintenance (such as mast, front and rear lights, etc.) to prevent pinching or slipping.
 - Be careful do not be scalded when inspecting the motor, controller and etc.
5. Whenever you discover a fault, stop the forklift, hang a "DANGER" or "OUT OF ORDER" sign on it, remove the ignition key and notify a manager. The truck may only be used after the fault has been eliminated.
- Arrange for immediate repair in the event of a fault when lifting or driving uphill or downhill, or a leakage of battery electrolyte, hydraulic oil or brake fluid.

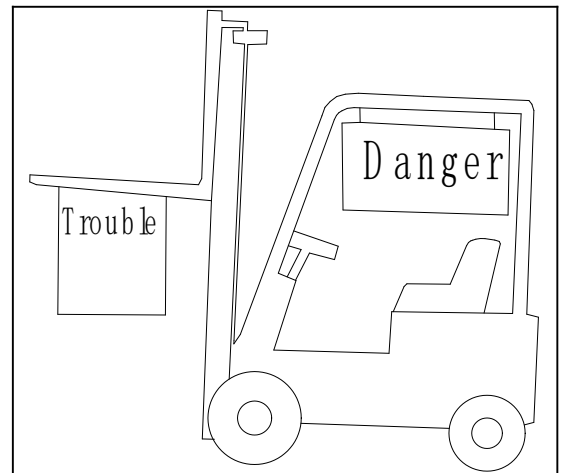

6. Batteries generate explosive gases. Keep sparks and open flames away from the battery. Keep tools away from the battery terminals to prevent sparks or short-circuits.

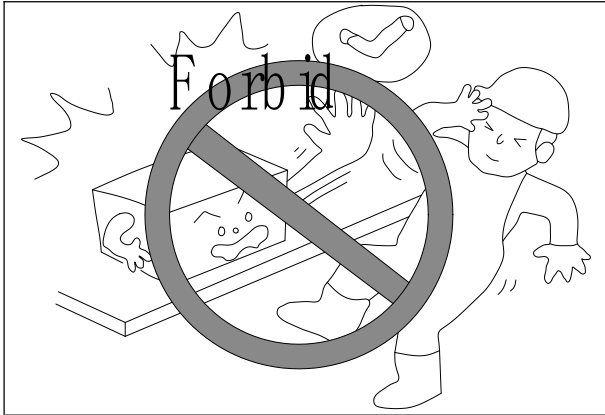

7. The work ground of forklift shall be solid and smooth concrete surface or similar ones. Pre-check the ground condition of working site.

- The truck is designed to operate in the following climatic conditions: temperature range $-20\text{ }^{\circ}\text{C}$ to $50\text{ }^{\circ}\text{C}$; maximum wind speed 5 m/s; maximum relative air humidity 90% (at 20°C).
- The truck is not suitable for use in flammable or explosive working environments.
- Altitude not exceeds 2000m.

8. Do not get on or off the running forklift.

Please use the safety pedal and armrest.

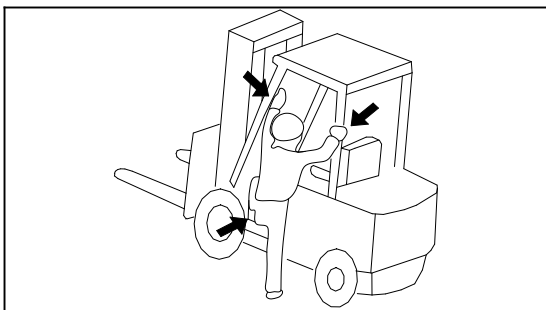

9. Never attempt to work the controls unless properly seated.

- Before starting the vehicle, adjust the seat

position to facilitate hand and foot control.

10. Before starting up, make sure that:

- The seat belt is fastened;

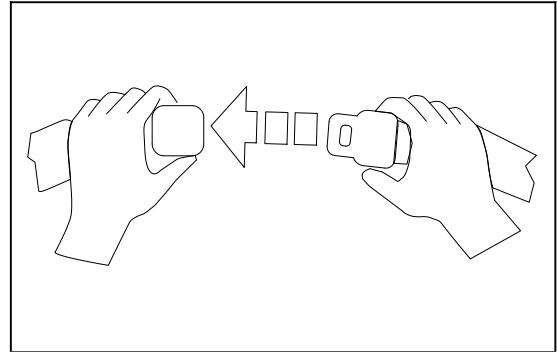

- The hand brake is released;
- The direction lever is in neutral;
- No person near the forklift.
- Before turning on the power, do not depress the accelerator pedal or operate the lift or tilt levers
- Operate the controls smoothly and do not jerk the steering wheel. Avoid sudden stops, starts or turns. Sudden braking may cause the vehicle to tip over. Jumping is prohibited when the vehicle tips over.

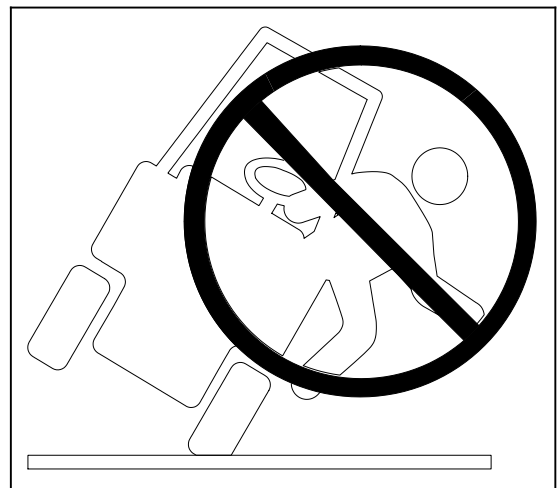

11. Always look in the direction of travel and keep a clear view of the travel path.

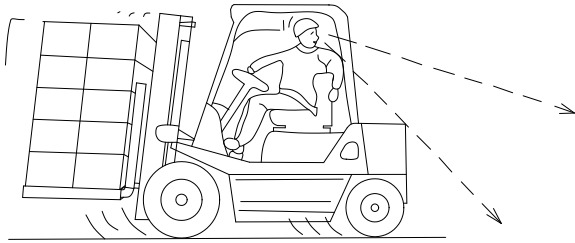

Warning

When reverse pay attention to driving direction.

Warn

It is especially important to look in the direction of travel when reversing.

12. Select appropriate attachments and tools according to the shape and material of the loads to be handled.

- Do not lift loads by suspending ropes from the forks or attachment, as the ropes may slip off. If necessary, arrange for a lifting hook or jib to be attached by someone qualified to perform heavy lifting tasks.
- Be careful not to let the forks touch the floor, so as to avoid damaging the fork tips or driving surface.

13. Know the load capacity of the forklift and attachments, and never exceed it. Do not use people as an additional counterweight.

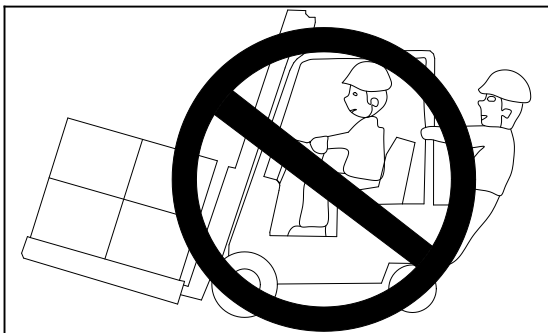

14. While driving, do not use mobile phones

or other electronic products, and concentrate on work.

15. Keep your head, hands, arms, feet and legs in the cab, and do not extend them for any reason.

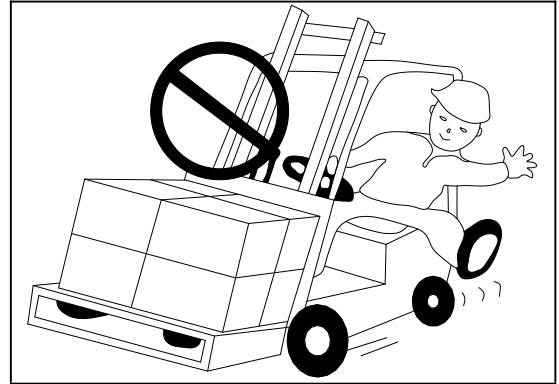

16. Pallets and skids should be strong enough to bear the weight of the load. Never use damaged or deformed pallets.

17. Hangcha can provide users with a variety of attachments including rotating clamps, flat clamps, side-shift forks, jibs, etc. Such attachments are for special uses only. Modifications to attachments must be authorized by the manufacturer. Do not attempt to modify attachments yourself.

18. The overhead guard prevents cargo from falling onto the operator. The load bracket ensures the stability of loads. Do not use a forklift without the overhead guard and load bracket.

19. Never permit anyone to walk or stand under upraised forks or attachments. Do not allow anyone to stand on the forks. If it is unavoidable, choose a safe place and use wooden blocks to support the forks or attachments to prevent accidents.

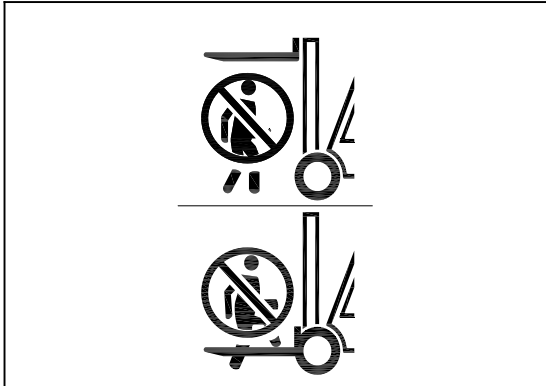

20. Never place your head or body in between the mast and overhead guard. Risk of serious injury or death due to entrapment.



21. Off-center loads may fall easily when turning corners or driving on uneven surfaces and increase the risk of the vehicle tipping over.

22. Do not stack loads on forks in such a way that the top of the load exceeds the load bracket height. If unavoidable, make the load stable and secure. When handling bulky loads which restrict your vision, operate the forklift in reverse or have a guide. When using a guide, make sure you know and understand the meaning of all hand, flag, whistle or other signals being used. When transporting long loads such as lumber, piping and oversized cargo, or operating vehicles with elongated

attachments, pay close attention to the front end when driving around corners or along narrow aisles and be aware of other people.

23. Try to reduce the front tilting angle when stacking goods, you can only tilt forward when the goods are higher than the stacking floor or at a low position.

- When stacking loads on a high place, make the mast vertical at a height of 15–20cm above the ground and then lift the load. Never attempt to tilt the mast when the load is raised high.
- To remove loads from high places, insert forks into the pallet, lift slightly and drive backwards, then lower the load. Tilt the mast backwards after lowering. Never attempt to tilt the mast with the load elevated.

24. It is dangerous to travel with the forks elevated, regardless of whether loaded or not. When travelling, the forks should be 15–30 cm from the ground with the mast tilted backward. Do not operate a sideshift mechanism when the forks are raised and loaded. This will cause the forklift to be unbalanced.

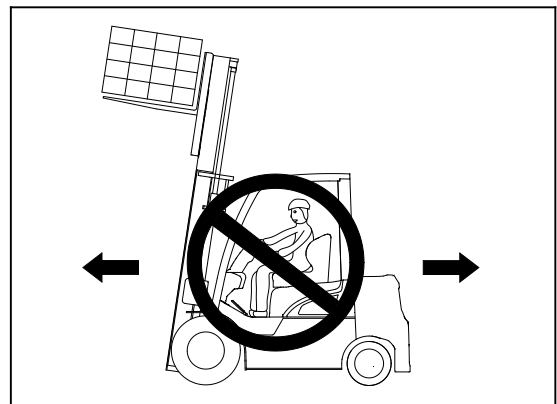

25. Do not tilt the mast forward when the cargo is raised.

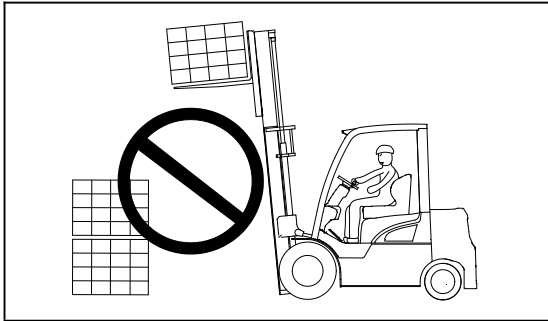

26. When operating in congested areas, be aware of intersections, trailing ropes, entrances/exits and hanging objects.

- Slow down and sound the horn at cross aisles and other locations where vision is obstructed.
- Turning speed should be limited to 1/3 of the vehicle's top speed.

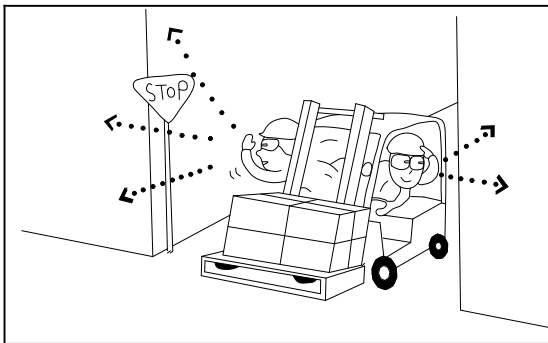

27. Make sure to keep your distance from the roadside or platform edge.

28. When driving over a ship's gangway or a bridge, make sure that it is properly secured and strong enough to withstand the weight of the forklift.

29. When operating a loaded forklift, reverse downhill, and climb forward.

- When operating an unloaded forklift, reverse uphill, and go downhill.

- Do not turn on ramps to avoid tipping over

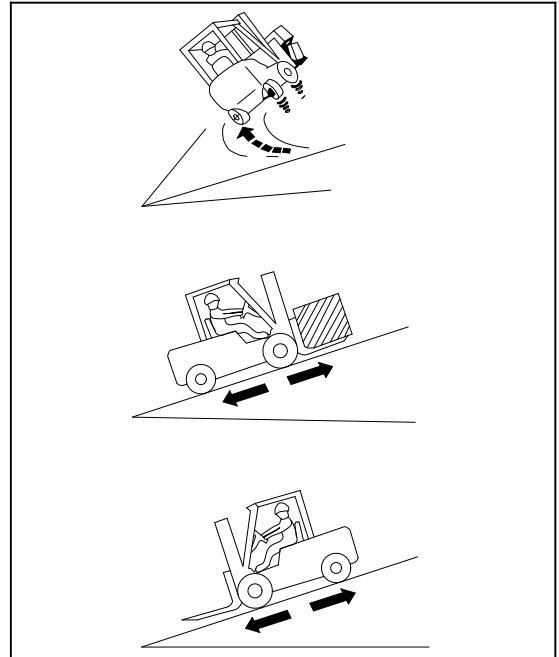

30. Goods are not allowed to deviate from the fork center, when goods are deviating from the fork center, turn or pass uneven road, they are easily to fall. Meanwhile, possibility of tipping over will increase.

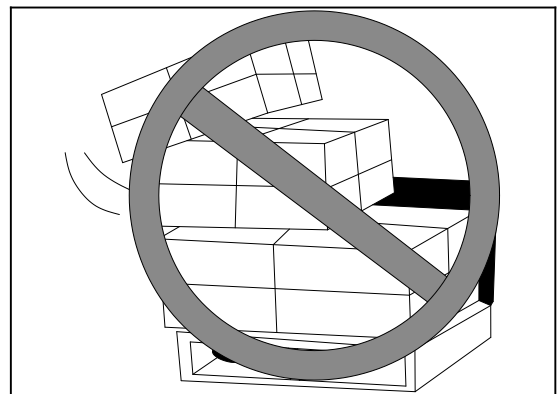

31. It's forbidden to lift goods on tilting roads. Do not load on the ramp.

32. Inspect the surface over which you will run. Look for holes, drop-offs, obstacles, protrusions and anything that might cause loss of control or bumps.

- Clear away rubbish and debris and pick up items that might puncture a tire or unbalance the load.
- Slow down on wet/slippery areas. Do not drive near the edge of the travel path; if unavoidable, be extra cautious.
- Do not use the forklift during sandstorms, snowfall, lightning, torrential rain, typhoons or other harsh weather conditions. Above all, avoid using the forklift where wind speeds are greater than 5 m/s.

33. Controller is equipped with accumulator. It's forbidden to touch within B+ and B- to prevent from wounding by electricity. To check or clean the controller, please disconnect the power supply of the whole vehicle first, and then connect a load (such as light bulb, resistor, speaker, etc.) between the controller B+ and B- to discharge the capacitor in the controller.

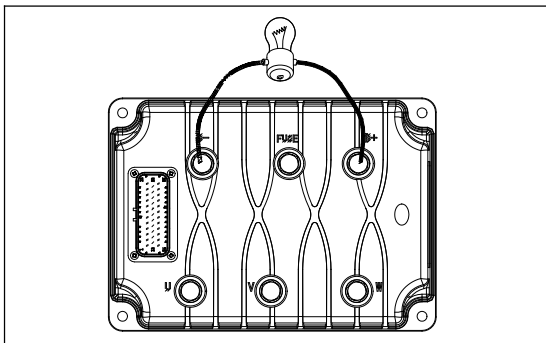

34. Park the forklift on a level surface and apply the handbrake securely. If parking on the ramp is unavoidable, be sure to block the wheels.

- Lower the forks to the floor and tilt slightly

forward. Turn off the key switch and remove the key.

- Disconnect the battery plug.
- Park the forklift away from naked flames and sparks.

35. When the truck is unable to drive, drag the truck to a safe place. Do not tow a truck whose steering system or braking system has been damaged.

36. The labels and signs on the vehicle provide warnings and operating instructions. During operation, adhere to the requirements of the manual as well as the labels and signs on the vehicle. Inspect the labels and signs, and replace damaged or missing ones.

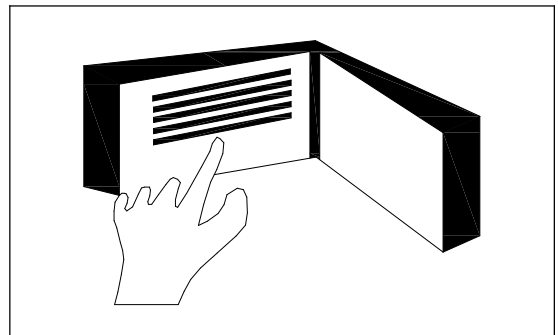

37. The workplace should be equipped with fire extinguishers. Users can also select a vehicle equipped with fire extinguisher. The fire extinguisher is generally installed on the rear leg of the safety frame and is easily accessible. Drivers and managers need to be familiar with the location and use of fire extinguishers.

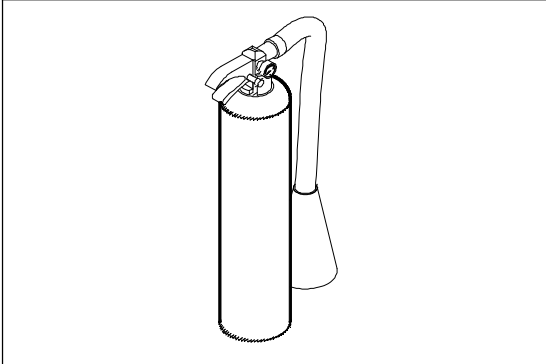

38. Small loads should be carried on a pallet and not placed directly onto the forks.

39. Refrigerator type truck is not allowed to store in the refrigerator when power off.

40. Maintain 3-point contact with the vehicle when getting on and off. When getting on and off the vehicle, always keep one hand and both feet in contact with the vehicle, or both hands and one foot in contact with the vehicle. Hold nothing in your hands (i.e. food, drink, tools).

3 Operation and safety precautions for the electric forklift lithium battery

| | |
|--|--|
| | 1. Contact the manufacturer immediately in case of battery malfunction. Do not open the battery cover for maintenance. |
| | 2. Do not reverse charge. |
| | 3. Whether it is charging or discharging, it should be ensured that the battery management system is properly connected and working normally, and the communication of the battery management system is normal. |
| | 4. Do not operate the equipment in a location where static electricity and magnetic field is strong. Or it may damage safety protection device, and lead to potential safety hazard. |
| | 5. The battery system or battery box should be kept away from heat, fire, and direct sunlight for a long time. It is also not allowed to directly bake and heat the lithium battery by hot water, otherwise it will cause an explosion. It is not allowed to work in a high temperature environment. |
| | 6. It is forbidden to place the battery pack in water or high humidity environment to avoid leakage or insulation failure. |
| | 7. When working in a low temperature environment, the capacity of the battery system is slightly reduced, which is a normal phenomenon, and the performance will recover when the ambient temperature rises. |
| | 8. Unauthorized modification or dissection of the battery system and battery box is prohibited to avoid danger. Non-professionals are not allowed to disassemble it without authorization to prevent foreign objects from entering the battery pack, causing combustion and explosion. |
| | 9. Lithium batteries have special chargers, and other types of chargers should not be used to charge them, so as not to damage the lithium batteries. |
| | 10. Do not connect the battery with the battery of other type in series or in parallel. |
| | 11. Prevent water ingress and corrosion of diagnostic ports and connectors. etc. |
| | 12. It is forbidden to mix the battery box with batteries of other types or other manufacturers. |
| | 13. It is forbidden to directly connect the positive and negative electrodes of the battery box or battery system with metal or other conductors to avoid ignition or short circuit; it is also forbidden to contact and mix the battery pack with items that can cause short circuits. |
| | 14. Avoid mechanical damage to the battery box, such as extrusion, puncture, shock, impact, etc. |
| | 15. If there is dust, metal chips or other debris on the top cover and pole of the battery |

| | |
|--|--|
| | pack, use compressed air or dry cloth to clean it in time. It is forbidden to use water or objects soaked in water for cleaning. |
| | 16. The working place is equipped with water-based fire extinguishers |
| | 17. If the temperature of the battery system rises sharply, the smell is abnormal, etc., stop the vehicle immediately and turn off the power. If smoke or fire occurs, stop the vehicle, turn off the power supply, and use a water-based fire extinguisher to put out the fire under the condition of ensuring the safety of personnel. |
| | 18. Charge in a well-ventilated, dry environment. |
| | 19. Charging working temperature: 0 °C -45 °C ; Discharging working temperature: -20 °C -55 °C ; Short-term storage temperature range: -20 °C -40 °C Long-term storage temperature range: 0-25°C Working humidity range: 5%-80% Storage humidity: <=70% |

Daily charging of lithium battery forklift

| |
|--|
| 1. When the power level of the forklift meter shows 1~2 bars of power (that is, the remaining 20%~30%) of power, charge it in time. |
| 2. Turn off the power switch of the forklift truck and press the emergency stop switch. |
| 3. Close the charger main input valve, make sure the emergency stop button bounce, the charger turns on automatically, the indicator illuminates, and the display screen starts automatically. |
| 4. Remove the charging gun, press the button lock before pulling it out. Check the charging gun, make sure no water or debris on each port, or metal terminal damaged or influenced by rust or corrosion. |
| 5. Open the side door, open the rechargeable lithium battery cover. Check the charging socket, make sure no water or debris on each port, or metal terminal damaged or influenced by rust or corrosion. |
| 6. Insert the charging gun into the lithium battery socket, the charger self checks and communicate with the lithium battery, when the entire system is fault-free, in about 15S, the inner relay attracts, start charging, and the charging indicator illuminates, while the instrument will display charging voltage, charging current, charging time and charging failure information. |
| 7. The charger will automatically stop charging after fully charged, output voltage and output current on the meter is 0, press the pause button, and then press charging gun lock and pull the charging gun out. If it needs stop charging without being fully charged, first press the pause button, wait until the charge current is reduced to 0A, and then press charging gun lock and pull the charging gun or plug out. |
| 8. Insert the charging gun to the charger lay-down position, and pull down the charger main input valve to close it. |
| 9. Close the lithium battery charging cover and the charging door on the truck body. Plug into the vehicle's electrical outlet and close the cover. Note: It is forbidden to insert the discharge plug of the battery into the charging socket, otherwise there is no power supply for the forklift line. |

Daily maintenance of lithium battery

| | |
|---------|--|
| Daily | 1. Check whether the appearance is deformed, whether the surface is oxidized, whether the paint is peeled off, whether the installation position is offset, whether the box is damaged, etc. |
| Weekly | 1. Use a dry cloth or compressed air to clean lithium batteries, chargers. |
| Monthly | 1. Check whether there is water or foreign matter in the plug and socket, and check whether it is rusted or burnt, etc. |

| | |
|-------------------------|--|
| | 2. Check whether the cable is damaged, whether the connector is loose, etc. |
| | 3. Check the battery casing for cracks, deformation, bulging and other abnormalities. |
| Lithium battery storage | 1. The battery is stored in a clean, dry and ventilated indoor environment with an ambient temperature of $20^{\circ}\text{C} \pm 5^{\circ}\text{C}$ and a relative humidity of not more than 75%. It should not be inverted, avoid mechanical shock and heavy pressure. |
| | 2. Charge once a month. |
| | 3. The positive and negative terminals of the battery box are wrapped with high-voltage insulating sleeves or other insulating materials to ensure that no metal parts are exposed to the outside to avoid short circuits. The diagnostic port is free of dust and wrapped or covered. |

4 Truck lifting, carrying and towing

4.1 Lifting

Securely fasten wire ropes to the lifting holes in both ends of the outer mast crossbar and to the counterweight hook, and then hoist the forklift with a lifting device. The wire rope fastened to the counterweight end must pass through the gap in the overhead guard, without putting stress on the overhead guard.

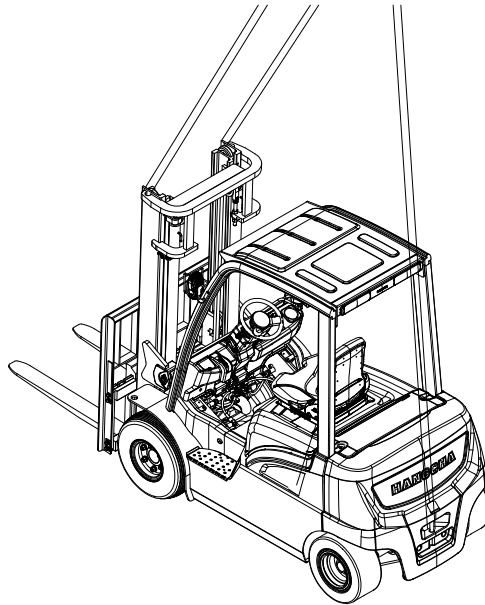
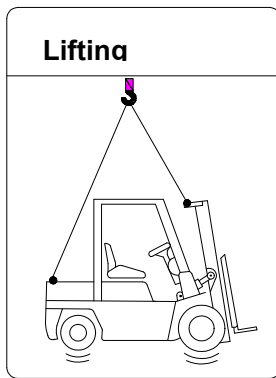

Securely fasten wire ropes to the lifting holes in both ends of the outer mast crossbar and to the counterweight hook, and then hoist the forklift with a lifting device. The wire rope fastened to the counterweight end must pass through the gap in the overhead guard, without putting stress on the overhead guard.



Warning

- Only use the lifting tools with enough load.
- Fully tilt the mast backward when lifting.
- When assembling lifting tool, notice that the lifting tool will not touch forklift part or overhead guard when lifting.
- Do not lift a forklift by its cab frame (overhead guard).
- Never walk under a forklift when it is being lifted.

4.2 Carrying

Forklift trucks are generally used for loading, unloading and short-distance transportation. They are not designed to be a long-distance mode of transport. A forklift that needs to be transported over a long distance should be transported in a ship, train or a truck having a load capacity over 5T.

Steps:

- Park the forklift on the lorry or trailer, and apply the parking brake.
- Tie the tension belt to the mast upper beam and counterweight tow pin, and use clamping device to strain the tension belt.
- Block the front and rear wheel of the forklift with wedge wood.

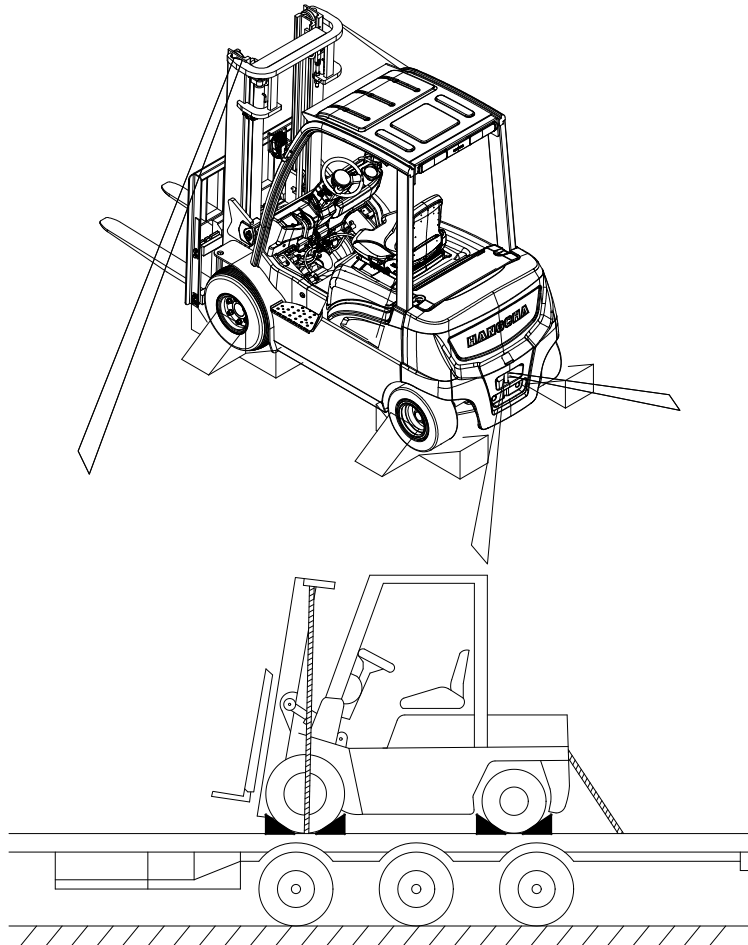



Warning

- When fixing forklift, take effective measures according to specific condition to guarantee the safety of transportation.
- Correctly fix the forklift when transporting by lorry or trailer.
- Chock the forklift to avoid accident movement.
- Only use tension belt with big enough nominal strength or fasten the belt to fix the truck.

4.3 Towing

Forklift is not permitted to use for daily traction or traction task

Towing pin in the lower counterweight is only used for the following occasions:

- Forklift malfunctions on the working road and move the truck urgently.
- Use when forklift gets into trouble and cannot drive(wheels get stuck in pits etc.)

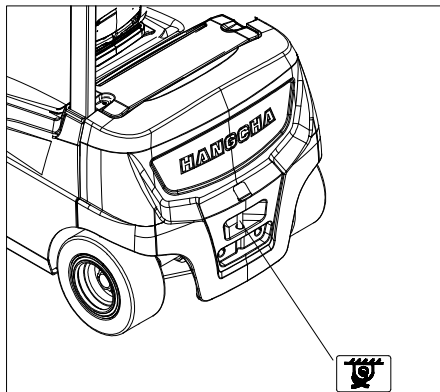

Steps:

- Turn off the key switch and disconnect the power plug.
- Release the parking brake.
- Put the direction lever in neutral.
- Fasten the wire rope for traction.

It can drag the forklift.



Warning

- **Do not tow the forklift with abnormal steering system and damaged braking system.**
- **Don't carry a load to steel wire ropes suddenly.**
- **Towing the forklift while the power is on will damage the controller.**

5 Lithium battery

5.1 Safety notice

1.1 It is strictly forbidden to touch the positive and negative poles of the battery box with both hands at any time to prevent electric shock.



1.2 Maintenance personnel are required to hold a qualified electrician certificate issued by the Safety Supervision Bureau and an ENEROC maintenance authorization to carry out maintenance operations.



1.3 Wear insulating gloves when operating and maintaining the battery system, and it is strictly forbidden to wear metal accessories such as watches.



1.4 When cleaning the vehicle, it is forbidden to directly flush the battery system to prevent the battery system from malfunctioning after water enters.



5.2 Installation instructions

2.1 Installation instructions, installers need to hold certificates, wear labor protection supplies, and pay attention to safety protection. Before installing the battery system, ensure that the low-voltage connectors of the battery system are disconnected from the vehicle components. Pay attention to safety protection when connecting the power high voltage to prevent the installer from getting electric shock during the installation process. When installing the battery system, it should be mechanically hoisted and slowly installed into the battery compartment of the vehicle. Be careful not to crush the electrical box and external cables. When connecting the battery system, avoid high voltage positive and negative polarity reverse connection, short circuit and other phenomena. To remove the battery system from the vehicle, make sure that the vehicle key is turned off, and the high-voltage cables, low-voltage connectors, and the vehicle are disconnected.

2.2 Check after installation. After the battery system is installed, check the limit pins and fixing bolts of the battery system to confirm that the battery system installation requirements are met. Check that the high-voltage cables and low-voltage connectors are correctly/reliably connected. Turn the vehicle key switch to the ON position, the relay should be able to attract normally and there is no battery alarm. If there is a battery failure alarm, you need to cut off the power immediately and notify our after-sales service

department to solve it.

5.3 Basic terms of lithium-ion power battery

3.1 Battery system

It usually includes one or more battery modules, battery management systems, thermal management systems, high and low voltage wiring harnesses, connectors and energy storage devices composed of structural components.

3.2 SOC

Refers to the percentage of remaining battery power.

3.3 Rated voltage

A suitable approximation of the battery voltage.

3.4 Rated capacity

The capacity value stated by the manufacturer that the battery can provide in a fully charged state under specified conditions.

3.5 Overdischarge

The state when the battery voltage is lower than the discharge cut-off voltage usually refers to the state entered after the battery is fully discharged and discharged.

3.6 Overcharge

The state when the battery voltage is higher than the maximum charging voltage can usually be regarded as the battery entering an overcharged state:

3.7 Explosion: The battery case is ruptured, and solid matter inside is rushing out of the battery, making a sound.

3.8 Fire: An open flame emerges from the battery case.

3.9 Leakage: The internal components of the battery (electrolyte or other substances) have leaked from the battery.

3.10 CAN communication: Control Area Network.

5.4 Usage notice

4.1 Battery temperature characteristics, working environment temperature: $-28^{\circ}\text{C}\sim 55^{\circ}\text{C}$, allowable charging temperature: $0^{\circ}\text{C}\sim 55^{\circ}\text{C}$, allowable discharge temperature: $-28^{\circ}\text{C}\sim 55^{\circ}\text{C}$, storage environment temperature: $-28^{\circ}\text{C}\sim 55^{\circ}\text{C}$.

4.2 Check before use, after the vehicle key switch is turned off, confirm that there is no battery system alarm information on the instrument panel. Please check the remaining power before use, it is recommended to use when the SOC is between 50% and 100%. If the SOC is lower than 30%, it is not recommended to continue to use it, please charge it as soon as possible.

4.3 Charging instructions, please charge in time if the battery system SOC is lower than 20%. Please use the special charging equipment authorized by the manufacturer for charging. If a fault alarm occurs during the charging process, both the battery system and the charger will stop charging, and the charger will display a fault message. The charging environment should be dry and ventilated, and there should be no flammable and explosive

materials around. The battery system should be fully charged once a week.

4.4 Long-term storage, before long-term storage, it should be confirmed that the battery system power is not less than 50%. Charge maintenance should be performed every three months: charge to 100%. If it has been stored for more than three months, please confirm whether there is any fault alarm in the power battery system before using it again. If so, please contact our after-sales service department for maintenance. Keep the storage environment as dry and ventilated as possible, and keep away from heat sources.



Caution

- When the ambient temperature is low, the charging time of the battery system will be prolonged, which is a normal phenomenon. In order to ensure the best performance of the battery system, the battery management system will automatically adjust the charging time as the temperature changes.

5.5 Daily maintenance

5.1 Appearance maintenance: Check the outer box of the battery system for foreign objects, obvious deformation, rust and other abnormal conditions.

5.2 Charging port maintenance: When the power is off, check the port for damage, foreign objects, rust and other abnormal conditions.

5.3 Connector maintenance: When the power is off, check whether the connectors are loose,

damaged or other abnormal conditions.

5.4 Status detection: Observe the battery system voltage, temperature and other status information on the charger display screen during charging to ensure that all status information is within the normal range.

5.6 Emergency plan

6.1 Extreme abnormal conditions: Users should establish a good awareness of safety precautions during use, and strictly prohibit illegal operations to avoid battery system abuse (overcharge, overdischarge, short circuit, extrusion, puncture, environmental overheating, high current discharge, etc.). During charging and using, the abnormal conditions that may occur in the power battery system: the battery system or local temperature rises sharply; any part of the battery system has abnormal smell or smoke

6.2 Emergency plan:

6.2.1 The personnel quickly leave the vehicle and call the police according to the situation at the scene.

6.2.2 Under the condition of ensuring personal safety, the following operations shall be carried out conditionally:

- a. If the external wiring harness is burning with smoke, use a carbon dioxide or dry powder fire extinguisher.
- b. If there is smoke inside the battery, use a high-pressure water jet at a distance.
- c. If smoke is inhaled, remove and seek medical attention as soon as possible.

6.2.3 Contact the vehicle brand dealer for professional advice.

5.7 Dimension/ Weight

| Type | Length (L) mm | Width (W) mm | Height (H) mm | Allowable lightest kg |
|---|------------------|-----------------|------------------|--------------------------|
| CPD20/25-XCY2-SI | 1084 | 620 | 412 | 180 |
| CPD30/35/38-XCY2-SI | 1064 | 761 | 412 | 230 |
| CPD20/25/27-XCY2H-SI | 1084 | 620 | 412 | 220 |
| CPD30/35-XCY2H-SI | 1064 | 761 | 412 | 320 |
| CPD15/18-XCY2-SI CPD020-XCXY2-SI | 1014 | 510 | 412 | 120 |

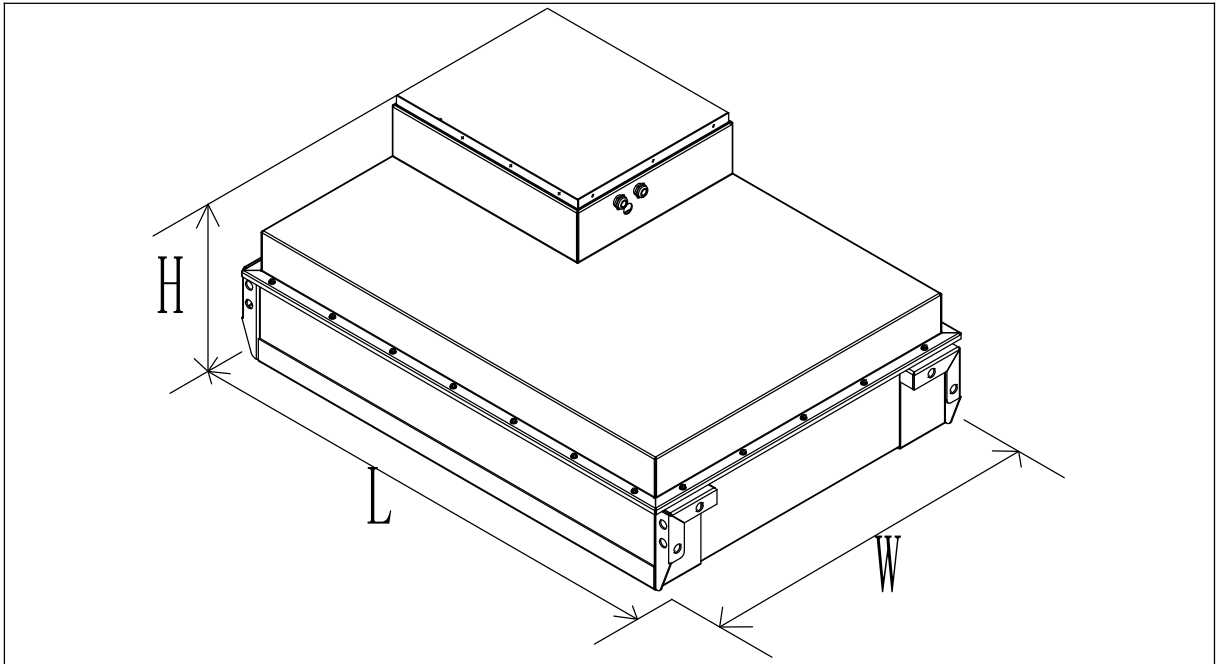

Warning

The weight and dimension of the battery have a great impact on the stability and carrying capacity of the vehicle's operation.

When installing or replacing the battery, pay attention to the fixed position of the battery on the vehicle, and the weight of the battery is within the range of the battery weight specified on the nameplate.

5.8 Charging of lithium batteries

This lithium battery forklifts can be equipped with two kinds of chargers: Titan intelligent charger.

5.8.1 Titan intelligent charger

Touch screen display interface





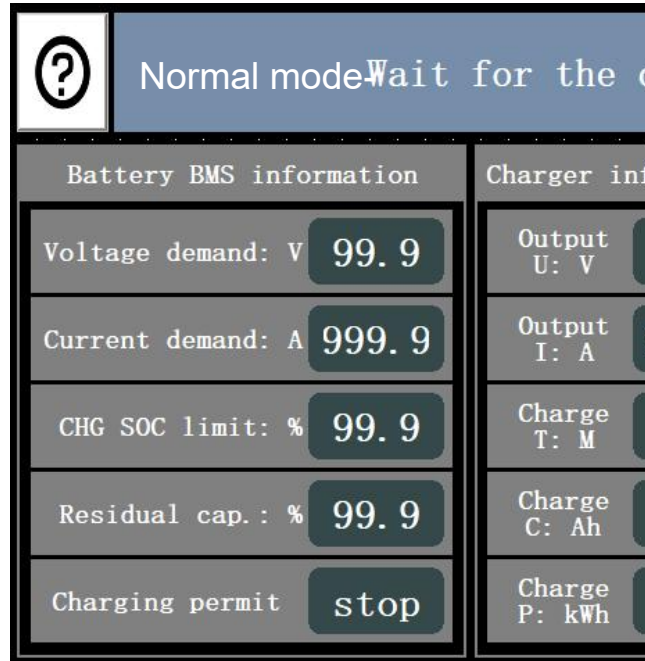

Start-up interface



Home page

Click the icon: , enter the help interface.

Click the icon:  or , switch the alarm sound on and off,  indicates that the alarm sound is turned on,  indicates that the alarm sound is turned off.

Password permissions are required for control operations, and the default password is: 123456.

Click the power-on icon: switch the charging control to on or off.

Click the purple part of the charging status information bar to enter the single charging module information display bar.

Click the battery BMS battery column to enter the detailed BMS information display column.

Click the mode switch to switch between

normal mode and reservation mode.

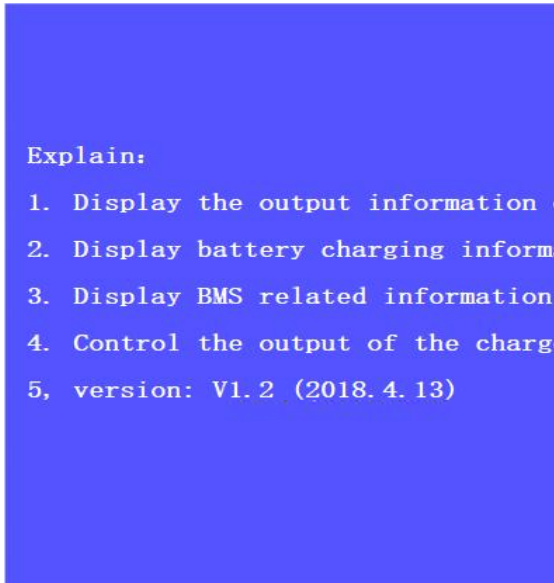

Help interface

Click the icon:  , return to the main interface.

Click the reservation icon to set the time of the appointment mode, and the password is 123456.

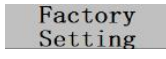
Click the icon:  , enter the password input interface. After the password is entered correctly, it will enter the factory parameter setting interface.

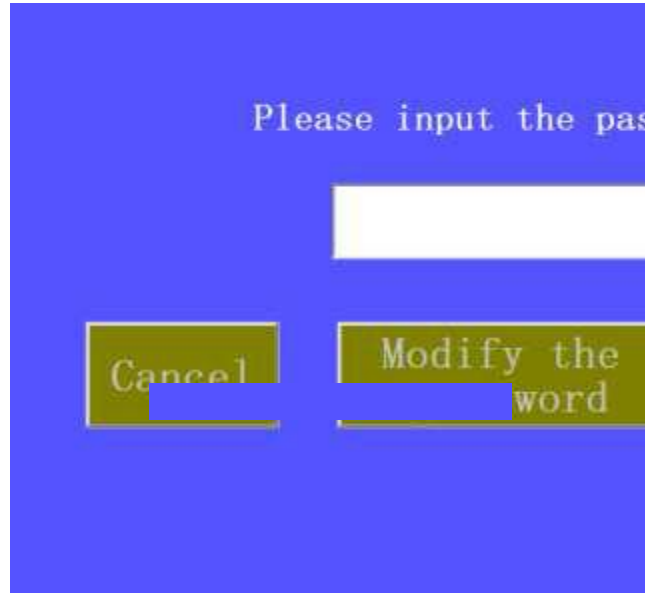

Password input interface

Enter the correct password in the password input box, the default password is 888888.

Click the icon:  , return to the help interface.

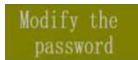

Click the icon:  , enter the password modification interface.

Click the icon:  , if the password is entered correctly, it will enter the parameter setting interface, otherwise it will prompt that the password is entered incorrectly, please re-enter.



Password change interface

Enter in sequence according to the prompts: the old password of the user, the new password for the first time, and the new password for the second time.

Click the icon: , if the old password is entered correctly, and the new password entered for the first time is the same as the new password entered for the second time, the modification is successful; otherwise, it will prompt that the modification fails, please re-enter. Click the icon: , return to the password input interface.

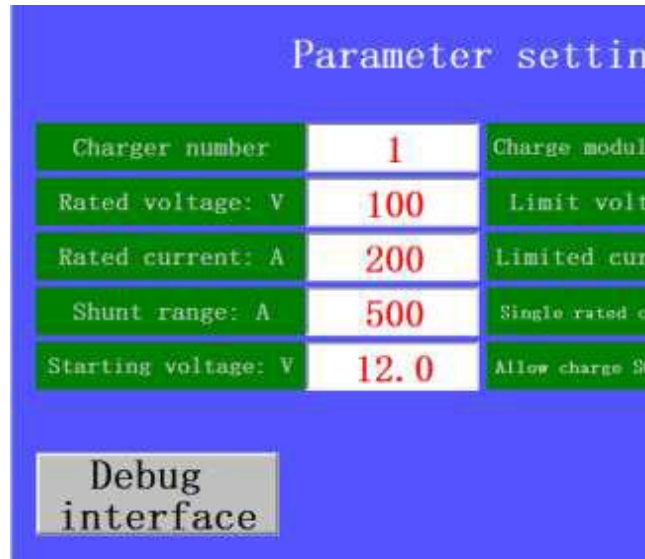

Parameter setting interface

Click the icon: , return to the help interface.

Parameter setting information: Rated voltage, rated current and shunt range are related to the machine hardware and cannot be modified arbitrarily after factory setting.

If the above parameters need to be modified, please consult the manufacturer. The charger number is convenient for users to distinguish, and users can set it at will. The debugging interface is for factory debugging, and users cannot operate it at will.

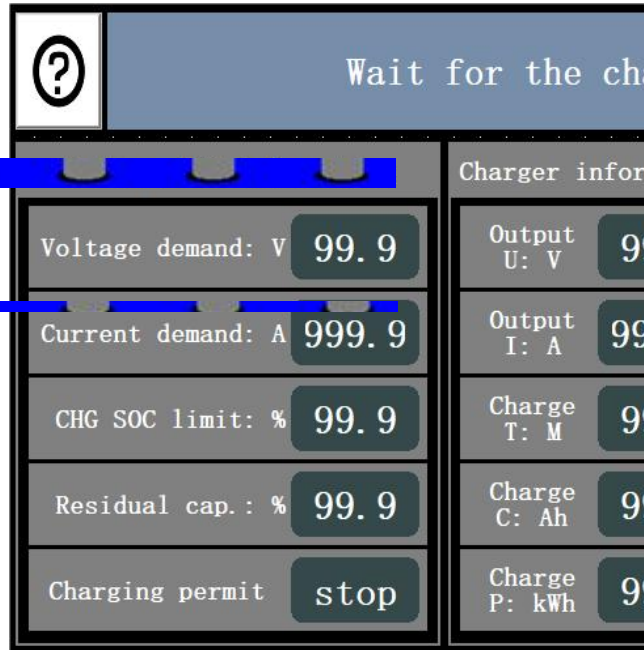
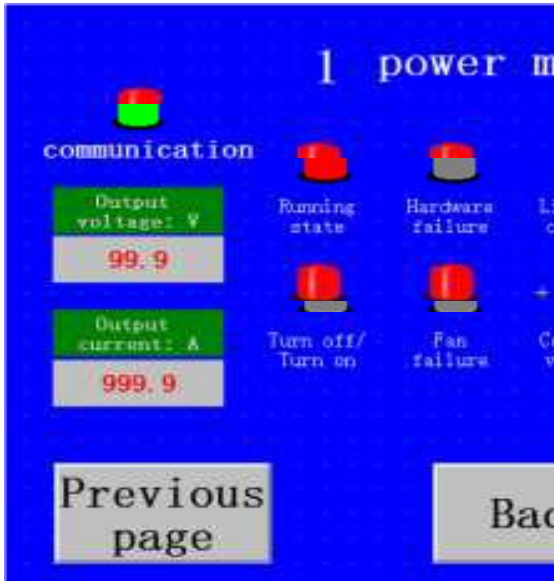

Power module display interface

Click the icon: Previous page, switch module information forward.

Click the icon: Back, return to the main interface.

Click the icon: Next page, switch module information backwards.

Display the output voltage, output current and various operating states of a single power supply module.

Detailed explanation of the charging process

Charging steps:

1. Select "On" charge control mode. The "CAN" and "485" indicators light green.
2. The DC charging gun is connected to the battery normally.
3. It starts charging when "residual capacity" is less than "allowable charging SOC limit".
4. The "Battery" indicator lights up in green (it lights up when the charger detects the battery voltage), and the "BMS" indicator lights up in green.
5. The "work" light is green, when the "output voltage" is close to the "battery pack voltage", the output relay of the charger attracts, and the charger starts to charge the battery. At this time, "output current" and

"output voltage" will be output according to "current demand" and "voltage demand".

6. After the BMS is charged, the charging termination command is sent, and the charger ends the charging.

7. During the charging process, the charger is faulty (the "overheat" and "abnormal" lights of the charger information are all charger faults), the BMS is fully charged or the "charging permission" is in the prohibited state, and the charging control is artificially in the "stop" state will terminate charging.

User wiring instructions



The AC input air switch switches the power supply of the whole machine. The input is the Yida plug, and the output is the charging gun

Warning: PE protection earth must be connected, otherwise it may threaten the safety of life.

Instructions

1. Precautions

a. Before the charger is turned on, it should be checked whether the battery box wiring is correct, whether there will be a short circuit or a positive and negative electrode connection. In order to avoid overloading the charger to burn components or lines.

b. It can be put into use only after the charger has no abnormal, overheating and other warning information.

c. For the safety of charging machines and equipment, it is forbidden to directly disconnect the battery switch under the condition of output current, except in case of emergency.

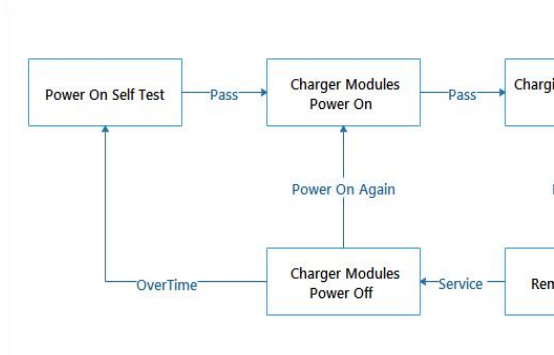

Operation flow chart

Power on self test: Make sure that AC input zero wire and DC output positive and negative electrode wiring are correct, and that there is no short circuit in input and output; The input voltage and frequency are normal; Always in a power-on state. Offline and online charging lines cannot be connected at the same time.

Power on: Check whether the AC fan wind direction is correct after the power is on. The touch screen can be turned on normally, communication with the charging machine is normal.

Connect battery: The battery voltage and current level meet the requirements of the charging machine. Battery polarity is not reversed. The battery is in good condition.

Power off: After the charging current and voltage drop to 0, exit the battery. Turn off the AC input air switch.

Charging procedures:

1. Stop the truck, turn off the key switch, and the truck is disconnected.
2. Close the charger main input valve, make sure the emergency stop button bounce, the charger turns on automatically, the indicator illuminates, and the display screen starts automatically.

| | |
|---|-----------------------|
|  <p>输入电总闸 长期不用时请关闭总闸</p> | Main input valve |
|  <p>急停开关</p> | Emergency stop button |
|  | Display screen |

3. Remove the charging gun, press the button lock before pulling it out. Check the charging gun, make sure no water or debris on each port, or metal terminal damaged or influenced by rust or corrosion.



4. Open the right door, and open the rechargeable lithium battery cover. Check the charging socket, make sure no water or debris on each port, or metal terminal damaged or influenced by rust or corrosion.



5. Insert the charging gun into the lithium battery socket, the charger self checks and communicates with the lithium battery, when the entire system is fault-free, in about 15S, the inner relay attracts, starts charging, and the charging indicator illuminates, while the meter will display charging voltage, charging current,

charging time and charging failure information.



6. The charger will automatically stop charging after fully charged, output voltage and output current on the meter is 0, press the pause button, and then press charging gun lock and pull the charging gun out. If it needs stop charging without being fully charged, first press the pause button, wait until the charge current is reduced to 0A, and then press charging gun lock and pull the charging gun out.
7. Insert the charging gun to the charger lay-down position, and pull down the charger main input valve.
8. Close the rechargeable lithium battery cover and truck charging door.

! Warning

The charger connector should only be inserted into the battery connector, never into the vehicle connector.

Precautions for the use and maintenance of lithium-ion power batteries

Basic battery requirements

- 1) In any case, the terminal voltage of the single battery must be detected in real time when testing or using the battery. It is strictly forbidden to perform a series charge-discharge test on the battery pack without a management system or a protection board, so as to avoid the overcharge or overdischarge of the battery.
- 2) Battery management system: In order to ensure the safe and effective use of the battery and maximize the service life of the battery, lithium battery products should be equipped with a special power lithium battery management system (BMS) and a special lithium battery charger. When a small number of small-capacity batteries are used in series, a reliable lithium battery protection board can also be used. The battery management system (BMS) is as follows:

| | | | | |
|-----------------------------|-------------------------------|-------|--|------|
| BMS parameter configuration | Overcharge protection voltage | 3.75V | Undervoltage protection voltage | 2.7V |
| | Maximum charging current | 200A | Overdischarge protection voltage | 2.2V |
| | Overcharge release voltage | 3.67V | Overtemperature protection temperature | 60°C |
| | Undervoltage release voltage | 2.8V | Overdischarge release voltage | 2.6V |

- 3) In the process of using the battery, it is strongly recommended to adhere to the principle of shallow charging and shallow discharging. The power is the most cost-effective when the power is between 30% and 100%. When the open circuit voltage of the single battery drops to 3.0V, the actual charge is less than 10%, charge the battery pack in time;
- 4) When testing or using the vehicle, you should always pay attention to observe the remaining power of the battery pack. Do not tow the vehicle back for charging when the power is exhausted. During the towing, auxiliary system like the on-board DC/DC (power supply for lights, wipers, etc.), steering assist and brake assist are still consuming power, and the battery will be over-discharged when the trailer is far away;
- 5) The high-voltage safety protection work of the battery pack must be done in place, the main circuit of the driving power and the low-voltage electrical circuit (including the vehicle body) must be properly isolated, and DC air circuit breakers and fast DC fuses with reliable performance should be selected:

- 6) It is strictly forbidden to draw power lines from individual batteries in the battery pack to supply power to the low-voltage electrical appliances in the vehicle, so as to avoid the consistency of the entire battery pack from being artificially damaged.

Precautions:

1. Lithium batteries should be charged immediately after each discharge to prevent battery power loss;
2. It is forbidden to place the battery pack next to hot and high temperature sources, such as fire, heaters and other equipment;
3. Do not operate the equipment in a location where static electricity and magnetic field is strong. Or it may damage safety protection device, and lead to potential safety hazard;
4. Avoid using the battery pack at high temperature (in direct sunlight) for a long time, otherwise it may cause the battery to overheat, function failure, and shorten its life;
5. Do not operate electric vehicles equipped with lithium batteries when the ambient temperature exceeds 55 °C; when the temperature is below -25 °C, the power battery system needs to be heated to above -10 °C before operating the vehicle;
6. Do not disassemble the battery box under any circumstances;
7. It is forbidden to fall, and it is strictly forbidden to knock the battery pack, etc.;
8. It is forbidden to short-circuit the positive and negative poles of the battery pack, and no foreign objects and tools should be placed on the lithium battery to prevent the battery from short circuit;
9. Do not directly wash the battery box to prevent water from entering the battery box and ensure the safety of the battery pack. It is forbidden to mix battery packs of different brands, capacities and types;
10. The battery pack should be stored in a cool, dry place away from direct sunlight.

Maintenance instructions:

1. Without the permission of the manufacturer, do not arbitrarily change the battery factory settings parameters
2. If it is necessary to interrupt or suspend charging during the charging process, do not plug and unplug it with power on, so as to avoid current arcing and damage to the charging base;
3. The charging time below 0°C will be longer than the normal temperature charging time;
4. If the battery is not used for a long time, the battery needs to be charged and discharged once a month. The best SOC range for battery storage is 50%-80%.

Common faults and solutions of batteries

The voltage is too low after the battery is fully charged

1. The battery has been stored out of use for a long time and has not been maintained in accordance with the regulations. Solution: Just charge the battery.

2. The battery has been subjected to a violent collision, characterized by damage to the outer of the battery case or the smell of electrolyte in the battery pack. Solution: This kind of situation is generally not within the scope of maintenance. If the maintenance is required, it is necessary to determine whether there is a problem with the output circuit or the battery itself. First, disassemble the battery case and check whether the P+/C+ and P-/C- wires or solder joints of the battery pack are damaged. If any damage, it needs to be replaced. Then use the method of incitement to determine the smell of the battery. If there is an irritating electrolyte smell, it means that the battery has leaked. It is necessary to test the voltage of each battery string of the battery. If the voltage of one string is too different from other groups and is very low, you need to contact the manufacturer to replace the battery of this string.

3. Insufficient capacity. Solution: Charge and discharge the battery, usually 3-5 times.

After the battery is fully charged (the charger shows full), the voltage is zero or low

1. Battery open circuit. Solution: Disassemble the battery, check whether the circuit is broken, check whether the solder joints are falling off, and repair the damaged area according to the situation.

2. The protective plate does not work. Solution: First, confirm whether the protection board cable is in good contact with the protection board, and observe whether the solder joints fall off. If there is no abnormality in the above conditions, test the voltage between B+B- and P+P-. If the voltage difference is large, it means that the protective plate is damaged. The protection board needs to be tested in detail. If the test fails, the protection board needs to be replaced.

Unstable battery voltage

1.Virtual welding. Solution: Use an internal resistance tester to test the internal resistance of the battery. If the internal resistance exceeds the specified value, there may be virtual welding inside the battery, and the battery needs to be disassembled and re-soldered.

2.The protective plate is abnormal. Solution: Replace the protective plate.

3.The terminals or connectors are in poor contact. Solution: replace the terminal or connector.

Can be charged normally but cannot be discharged normally or can be discharged normally but cannot be charged normally

1.The protective plate is broken. Solution: it needs to replace the protective plate.

Emergency plan

1. **Extreme anomalies that may occur during battery operation:** Users should establish a good sense of safety precautions during use, strictly prohibit illegal operations, and avoid battery system abuse (overcharge, overdischarge, short circuit, extrusion, puncture, environmental overheating, large current discharge, etc.) During charging and use, the battery system may appear the following anomalies:

- a. Sharp rise in battery system or local temperature.
- b. There is an abnormal odor anywhere in the battery system.
- c. Any part of the battery system smokes and catches fire.

2. Emergency measures in case of smoke or fire in the battery system during use, if smoke or open fire occurs in the battery system during use, it shall be handled in the following order:

a. Park and power off.

b. The personnel quickly evacuated the vehicle and called the police according to the scene situation.

c. Use water-based fire extinguishers to put out smoke or fire parts under the condition of ensuring personnel safety

d. Notify our company personnel as soon as possible.

6 Operating instructions

6.1 During running-in

New forklifts should run under low load in the initial stage of being put into use. In particular the following requirements should be met within the first 100 hours of operation:

- Battery over discharge must be prevented during initial use.
- Generally, it should be charged in time when it is 80% discharged.
- Required preventive maintenance must be carried out thoroughly.
- Avoid sudden braking, acceleration or cornering.
- Carry out oil changes or lubrication ahead of schedule in accordance with regulations.
- Limit the load weight to 70%–80% of the rated load.

6.2 Check and adjust before operation

For the safe operation of the forklift, the forklift must be checked and adjusted accordingly before operating the forklift.



Warning

- **If there is damage or potential risk on forklift or attachment after check, then do not operate the forklift before repairing.**
- **In addition to testing lights and checking operating performance, before checking the electrical system, turn off the key switch and disconnect the battery plug.**
- **Before operating the vehicle, the operator should be familiar with the unconventional operating conditions, in which additional safety precautions need to be taken, or special operating instructions should be followed.**

- Visual check the forklift, pay attention to the wheel, wheel bolt and load part if damage or loose.
- Visual and hand touch check that the transaxle, hydraulic system, brake system and battery for leaks or damage.
- Check the tire pressure: Use an air pressure gauge to check whether the tire pressure is at the specified value (2t~3.8t:9.0bar for the front wheel / 9.7bar for the rear wheel. 1.5t~X2.0t:08.6bar for the front wheel / 8.6bar for the rear wheel.).
- Check if the battery box is locked.
- Check whether the driver's seat functions normally, and adjust the seat position according to the actual situation of the driver.
- Adjust the front and rear and upper and lower positions of the armrest control device according to the driver's own situation.
- Check the correct function of the seat belt: The seat belt must be locked when pulled out quickly.
- Adjust steering column inclination.
- Adjust the rearview mirror view.
- Check if the lifting chain's tension is even.
- Check the function of operation and display element.
- Check whether the instrument display function is normal.

- Check the seat switch function: when driver does not sit down correctly, the seat switch indicator light on the instrument is on, and the hydraulic function cannot be operated.
- Check the steering system function
- Check if the brake pedal functions properly.
- Check the accelerator pedal: Depress the accelerator pedal, change with the stroke, the acceleration is strong and weak, and the return is good.
- Check the steering angle display: Turn the steering wheel to the end in both directions and check that the wheel position is displayed on the gauges.
- Check the hydraulic function of lifting and tilting and attachment
- Check whether the electrical components such as lights, horn, reversing buzzer etc. function properly.
- Check if the directional control switch is in zero or neutral position.

Check tire pressure (pneumatic tires only)

Screw down the nut cap in anticlockwise and measure the tire pressure with pressure gauge. Add pressure to specified value when insufficient. After confirming leakage free, screw the nut cap, check the tire's ground contact surface and sides for damage, and the rim for deformation.

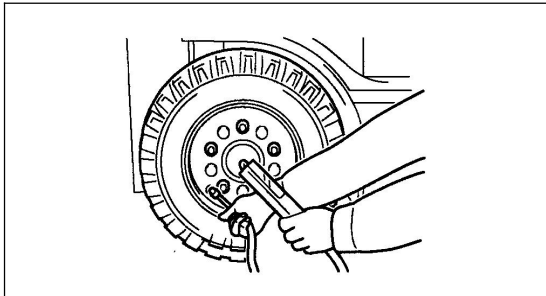

Warning

- Forklift tires need high pressure to support, and slight deformation of the rim or damage to the ground surface of the tire will cause an accident.
- When using the air compressor, you should firstly adjust the press, cause the max. output pressure of the air compressor is higher than the specified pressure of tire, otherwise, it may cause severe accidents.

Tire pressure (adopts new standard GB/T2982-2001)

| Model | Front wheel | Rear wheel |
|-----------|-------------|------------|
| 2.0t~3.8t | 0.9 MPa | 0.97 MPa |

| | | |
|------------|----------|----------|
| 1.5t~X2.0t | 0.86 MPa | 0.86 MPa |
|------------|----------|----------|

Note : The above is the pneumatic tire pressure, not suitable for solid tires.

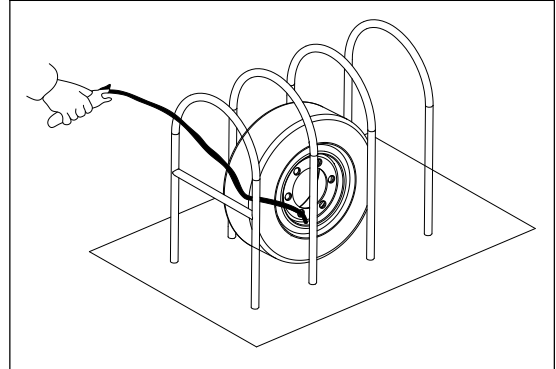

Warning

- After assembling tires and rims, all the bolts and nuts should be fastened to specified torque valve, then inflate the tires. Tires have expanding power after inflation, and the tire pressure should not exceed specified value.
- To ensure safety, you should place the tires in a protective frame or tie the tires with chain when inflation.

Check wheel fixation

Check whether the tightening torque of the front and rear wheel nuts meets the requirements.

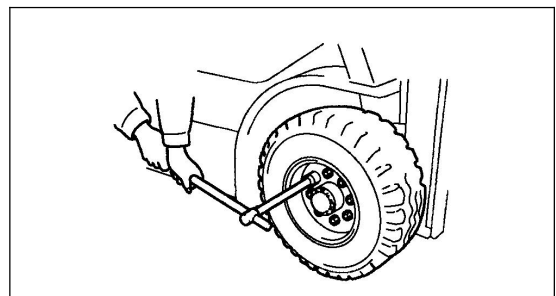

Steps:

- Park the truck.
- Screw down wheel retaining nut with spanner crosswise, see the table below for tightening torques.

| Model | Front wheel nut (Nm) | Rear wheel nut (Nm) |
|------------|----------------------|---------------------|
| 2.0t~3.8t | 441-588 | 157-176 |
| 1.5t~X2.0t | 157~176 | 76-107 |

Brake pedal check

Steps:

- Depress the brake pedal and check that it moves freely without jamming.
- The correct braking distance during unloading is 2.5 metres.
- Adjust pedal height: regulate the limit bolt so that the midpoint of the upper face of the pedal pad is 115-125mm from the front baseplate.
- Adjust the length of the pushrod of the brake master cylinder so that the pedal free play is 1-3mm.
- The brake light switch should turn on fully when the brake pedal is gradually depressed 10-20mm.

Hand brake lever check

The operating force is regulated by means of an adjusting screw on the rod tip. Twist clockwise to increase the operating force; twist anti-clockwise to reduce it.

Ensure that the hand brake handle is tightened,

and then loosened to return to the original position with good effect



Caution

- **Depressing the brake pedal helps to tighten or loosen the hand brake lever.**

Brake fluid check

Open the brake fluid cup lid and check whether the brake fluid level is between the scale marks. Top up if necessary. Also check for air trapped in the brake line.



Caution

- **Use pure brake fluid. Do not mix different grades of brake fluid.**
- **Do not spill brake fluid on painted surfaces, otherwise it will damage the paint.**
- **When adding brake fluid, avoid getting dust and water in the reservoir.**

Hydraulic oil check

Open the rear bottom plate and unscrew the hydraulic oil filler cap located on the right rear, pull out the dipstick and check whether the oil is between the marks. Add if necessary.

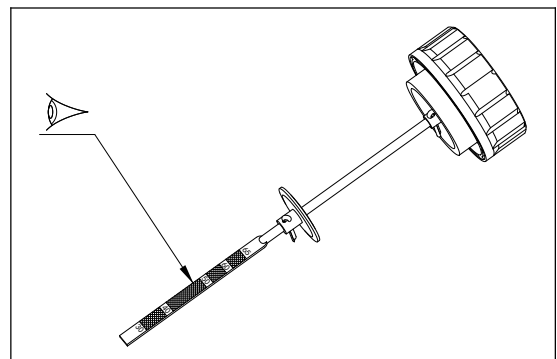

Different mast lifting heights correspond to the liquid level of the dipstick:

"30" means hydraulic height when lifting height $H \leq 3.0\text{m}$

"40" means hydraulic height when lifting height $H \leq 4.0\text{m}$

"50" means hydraulic height when lifting height $H \leq 5.0\text{m}$

"60" means hydraulic height when lifting height $H \leq 6.0\text{m}$

"65" means hydraulic height when lifting height $H \leq 6.5\text{m}$

Battery check

Check if the battery is fastened securely. That is, whether the battery is fixed firmly and reliably.

Check whether the plug and socket are loose or damaged, otherwise they should be adjusted or replaced.

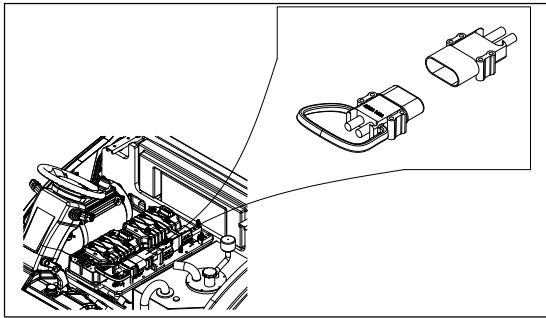

Check mast and fork

- Forks are not cracked or bent, and that they are firmly and correctly installed in the fork carriage;
- Check the oil cylinder and pipeline for leakage;
- Check that the rollers turn condition;
- Check the mast for cracks and

deformation;

- Operate the lifting, tilting and attachment levers, check if the mast operates normally and no noise.

Chain tension check

- Raise the forks to a height of 10–15cm with the mast vertical.
- Press the middle section of the chain with your thumb to check whether the tension between the left and right chains is identical.
- Tension adjustment: loose the lock nut and turn the adjuster nut to adjust the chains so that they both have the same tension, then tighten the lock nut.

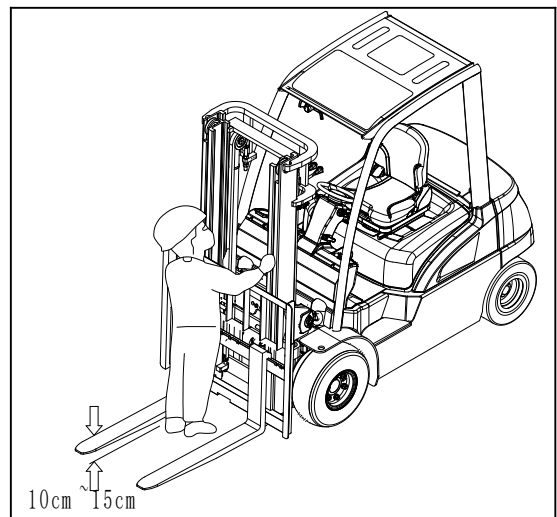

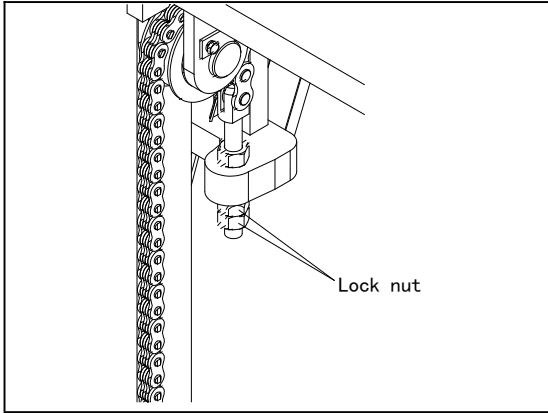

6.3 Operation

Starting and operation



Warning

Never start the truck before any damage or failure to the truck has been settled.

Starting

- Open the cover, connect the battery plug, and then close the cover.

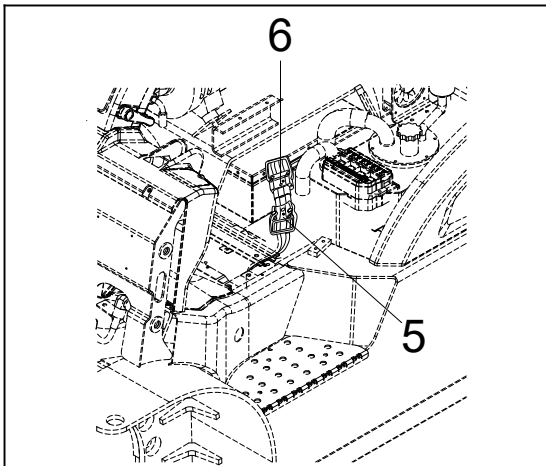

- Release the emergency stop switch. Rotate it clockwise for a certain angle, and the emergency stop switch button will automatically pop up.
- Put the direction lever in the neutral position.
- Insert the key into the switch lock and turn it to the right to the "I" stop.
- The forklift enters a 3-4 second self-check procedure, and the available battery power is displayed on the display after the self-checking is over.



Caution

The forklift will automatically enter the

self-check procedure (about 3 to 4 seconds). The welcome screen will be displayed on the display screen, and all 6 indicators will be on. The forklift cannot be driven and lifted during this time. If the direction switch or accelerator pedal or lift switch, etc. is operated during this period, a fault code will appear in the screen and the fault indicator "F" will light up.

- Hold the steering wheel handle firmly with your left hand and turn on the key switch with your right hand.
- Tilt mast backwards
- Operate the lifting lever to raise the forks 150 to 200mm off the ground. Operate the tilt lever to tilt the mast all the way back.
- Operate the direction lever
 - To drive forward: push the direction lever forward;
 - To reverse: pull the direction lever back.
- Release the hand brake lever:
- Depress the brake pedal, push the hand brake lever all the way forward.
- Grip the steering wheel knob with your left hand and slightly rest your right hand on the steering wheel.

Driving

Slowly depress the accelerator pedal until the forklift starts to travel forward or backward.

Decelerating

Slowly release the accelerator pedal, the forklift will slow down.



Caution

Always decelerate in the following situations:

- When turning;
- When approaching cargo or pallets
- When approaching stacked cargo areas;
- When entering narrow aisles
- When ground or road is in poor condition.

Warning

Never depress the accelerator pedal and the brake pedal at the same time.

Steering

A forklift is not like an ordinary vehicle in that it has rear-wheel steering, which means that the rear counterweight swings outward when cornering.

Decelerate, then rotate the steering wheel in the direction that you want to turn, slightly ahead of the vehicle with front-wheel steering.

Caution

Drive slowly and operate the steering wheel carefully. Ensure that there is sufficient room for the rear end to swing out when making the turn.

Parking

- Decelerate, then depress the brake pedal until the vehicle stops.
- Get the shift lever in neutral.
- Apply the hand brake.
- Lower the forks to the floor and tilt the mast all the way forward.

- Turn the key switch to the OFF position, disconnect the battery plug, remove the key and keep it in a secure place.

Caution

- Get off the truck carefully and do not jump.
- The vehicle must not be parked along driving routes.

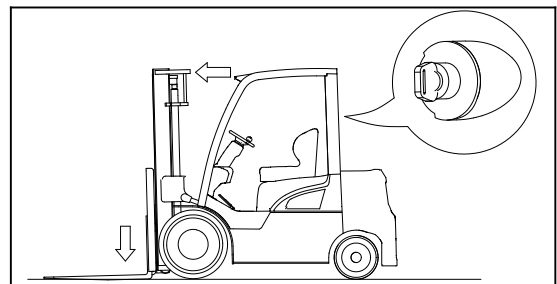

Loading

- Adjust the spacing between the forks to ensure a well-balanced load
- The vehicle is facing the cargo for loading.
- The pallet should be placed symmetrically on both forks.
- Insert the forks into the pallet as far as possible
- Lift the load:
 - First raise the forks 5–10cm off the ground and make sure that the load is secure.
 - Tilt the mast all the way back, raise the load 5–10 cm off the ground, then move off.
- When a bulky load restricts vision, except for climbing slopes, reverse the vehicle.

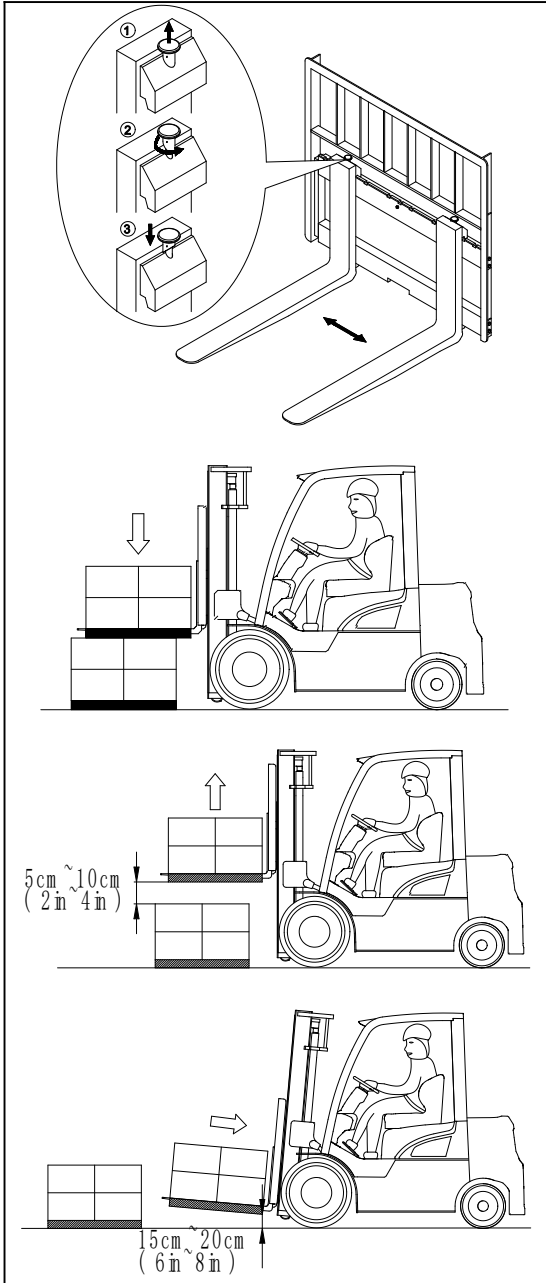

Stacking

- Slow down when approaching the deposit location.
- The vehicle is parked directly in front of the cargo storage area
- Check the condition of the storage place.
- The mast is tilted forward to the level of

the fork, and the fork is raised slightly above the unloading position.

- Travel forward, put the load on the unloading position and then stop.
- Make sure the loads are right above, drop the forks slowly until the forks are out of the load.
- To perform necessary lifting and tilting operations, reverse the forklift to remove the forks from the loads.
- After confirming that the fork tip has left the cargo, lower the fork to a position 15cm-20cm above the ground.
- The mast is tilted back into place.



Caution

Slow down the forklift in the following situations:

- When turning;
- When approaching cargo or pallets;
- When approaching stacked cargo areas;
- When entering narrow aisles;
- When ground or road is in poor condition.



Warning

- Do not tilt the mast when the load is raised above 2m.
- Do not get off or leave the vehicle when the load is at a high place.

Unloading

- Slow down when approaching the pick-up

location.

- Stop when the forklift is 30cm away from the load.
- Check the condition of the load.
- The mast is tilted forward to the level of the fork, and the fork is raised to the pallet or rack position.
- Make sure the fork is aligned with the pallet, move forward slowly, insert the fork into the pallet as much as possible and stop.



Caution

When it is difficult to insert the forks fully into the pallet, drive forward so that the forks are inserted to 3/4 of their length. Raise the forks by 5–10cm, back up 10–20cm, then lower the pallet or rack. Drive forward again until the forks are fully inserted.

- Raise the forks 5–10cm off the stack.
- Look around the vehicle to confirm that there is no obstacle, and then back up slowly.
- The fork should drop 15cm~20cm from the ground, the mast should be tilted back in place, and then transported to the destination.

Check before parking

- Stop the vehicle
- Fully lower the mast
- Set the direction switch to zero or neutral
- Apply the handbrake

- Turn off the power with the key switch, press the emergency stop switch to cut off the power.
- If the vehicle must be parked on a slope, chock the wheels with chocks.

Check after operation

After use, clean the forklift and carry out the following checks:

- Check for damage and oil leaks.
- Add lubricant if required.
- Check tires for damage and foreign bodies embedded in the treads.
- Check for loose hub nuts.
- Check the electrolyte level.
- If the forks have not been elevated to their maximum height during the day, after finishing work, raise them to their maximum height 2 to 3 times.



Caution

- If any fault is found, it should be repaired in time.
- Do not use the forklift until it has been fully repaired.

7 Maintenance

Careful, all-round maintenance will keep the forklift truck in good working condition. It guarantees the safety of the forklift and your personal safety at work.

7.1 Maintenance Summary

- The forklift must be regularly checked and maintained to keep it in good working order.
- Inspection and maintenance are often easily overlooked. Early detection enables problems to be settled in a timely manner.
- Use original Hangcha Group spare parts.
- Do not use different types of oil when changing or topping up oil.
- Waste battery, oil and battery fluid must not be poured away indiscriminately, but disposed in accordance with local environmental laws and regulations.
- Establish and follow a comprehensive maintenance and service schedule.
- Maintain complete records of all maintenance and service.
- Untrained personnel must not attempt to carry out forklift repairs.
- Modifications of forklifts by users may introduce hazards or risks not considered by the manufacturer and will invalidate existing forklift risk assessments.

The user may arrange for modification or modification of a powered industrial forklift only if the forklift manufacturer is no longer in business and there is no heir interested in the business, but only if the user needs to make the changes in accordance with the following requirements::

- (a) Arrange for modifications or retrofits designed, tested and implemented by engineers specialists in industrial forklifts and their safety,
- (b) Maintain permanent records of design, testing and implementation of modifications or changes;
- (c) Approve and make appropriate modifications to capacity plates, decals, labels and instructions;
- (d) Put a permanent and easily visible label on the truck that states how the truck was modified or changed, the date it was modified or changed, and the name and address of the organization that completed those tasks.



Caution

- No open flames.
- Turn off the key switch and disconnect the battery plug before carrying out any servicing or maintenance. (except when carrying out certain obstacle checks).
- Secure the pick-up device, inner mast and chassis, lift the drive wheels off the ground, and secure with chocks or other devices.
- Clean electrical parts with compressed air. Do not clean with water.
- Do not put your hands, feet or any part of your body between the mast and dashboard.

Counterweight weight:

| Tonnage | Counterweight weight |
|---------|-------------------------------|
| 2.0t | 1135kg (+40kg) |
| 2.5t | 1135kg (+40kg) +343kg (+20kg) |
| 2.7t | 1390 (+40kg) +343kg (+20kg) |
| 3.0t | 1900kg (+40kg) |
| 3.5t | 1900kg (+40kg) +350kg (+20kg) |
| 3.8t | 2060kg (+40kg) +350kg (+20kg) |
| 1.5t | 805kg (+40kg) |
| 1.8t | 805kg (+40kg) +230kg (+20kg) |
| X2.0t | 1230kg |

7.2 Regular maintenance schedule

○ — check, correct, adjust ×— replace

Electrical system

Lithium battery

| Item | Service required | Tool | Daily (8h) | Weekly (40h) | Monthly (166h) | Every 3 months (500h) | Every 6 months (1000h) | Annually (2000h) |
|-----------------|---|------|------------|--------------|----------------|-----------------------|------------------------|------------------|
| Lithium battery | Lithium battery installation and fastening | | ○ | ○ | ○ | ○ | ○ | ○ |
| | Lithium battery charging socket cleaning | | | | ○ | ○ | ○ | ○ |
| | Whether the contacts of the lithium battery charging socket are damaged or corroded | | ○ | ○ | ○ | ○ | ○ | ○ |
| | Whether there is water in the contacts of the lithium battery charging socket, clear it | | ○ | ○ | ○ | ○ | ○ | ○ |
| | Whether the dust cover of the lithium battery charging socket is in good condition | | | | ○ | ○ | ○ | ○ |
| | Whether the lithium battery casing is damaged | | ○ | ○ | ○ | ○ | ○ | ○ |
| | Battery power | | ○ | ○ | ○ | ○ | ○ | ○ |
| | Keep away from flames | | ○ | ○ | ○ | ○ | ○ | ○ |

Controller

| Item | Service required | Tool | Daily (8h) | Weekly (40h) | Monthly (166h) | Every 3 months (500h) | Every 6 months (1000h) | Annually (2000h) |
|------------|---|------|------------|--------------|----------------|-----------------------|------------------------|------------------------|
| Controller | Check condition of contacts | | | | | ○ | ○ | ○ |
| | Check mechanical movement of contactors | | | | | ○ | ○ | ○ |
| | Check pedal microswitches are functioning properly | | | | | ○ | ○ | ○ |
| | Check condition of connections between motor, battery and power unit | | | | | ○ | ○ | ○ |
| | Check controller faults to determine whether system is functioning properly | | | | | | | 2 years for first time |

Motor

| Item | Service required | Tool | Daily (8h) | Weekly (40h) | Monthly (166h) | Every 3 months (500h) | Every 6 months (1000h) | Annually (2000h) |
|-------|---------------------------------------|------|------------|--------------|----------------|-----------------------|------------------------|------------------|
| Motor | Clear foreign bodies on motor housing | | | | ○ | ○ | ○ | ○ |
| | Clean or replace bearings | | | | | | ○ | ○ |
| | Wiring correct and secure | | | | ○ | ○ | ○ | ○ |

Other electrical system

| Item | Service required | Tool | Daily (8h) | Weekly (40h) | Monthly (166h) | Every 3 months (500h) | Every 6 months (1000h) | Annually (2000h) |
|--------------------------------------|--|------|------------|--------------|----------------|-----------------------|------------------------|------------------|
| Emergency power off button | Work and installation | | | ○ | ○ | ○ | ○ | ○ |
| Operator presence sensing | Work and installation | | | ○ | ○ | ○ | ○ | ○ |
| Rocker switch | Rear headlights, | | | ○ | ○ | ○ | ○ | ○ |
| Reversing switch | Work and installation | | | ○ | ○ | ○ | ○ | ○ |
| Combination switch (steering, light) | Work condition of left and right turn signal | | | ○ | ○ | ○ | ○ | ○ |
| | Lighting gear, and working conditions | | | ○ | ○ | ○ | ○ | ○ |
| Horn | Work and installation | | ○ | ○ | ○ | ○ | ○ | ○ |
| Lights and bulbs | Work and installation | | ○ | ○ | ○ | ○ | ○ | ○ |
| Reversing buzzer | Work and installation | | ○ | ○ | ○ | ○ | ○ | ○ |
| Meter | Meter work condition | | ○ | ○ | ○ | ○ | ○ | ○ |
| Electrical cables | Harness damage, looseness | | | ○ | ○ | ○ | ○ | ○ |
| | Circuit connection looseness | | | | ○ | ○ | ○ | ○ |

Truck body system

| Item | Service required | Tool | Daily (8h) | Weekly (40h) | Monthly (166h) | Every 3 months (500h) | Every 6 months (1000h) | Annually (2000h) |
|---------------------|--|----------------|------------|--------------|----------------|-----------------------|------------------------|------------------|
| Frame and side door | Whether the frame is cracked | | | | ○ | ○ | ○ | ○ |
| | Whether the right door latch assembly works well | | ○ | ○ | ○ | ○ | ○ | ○ |
| | Whether the right door is well opened | | | | ○ | ○ | ○ | ○ |
| | Fastening of guard rod | | ○ | ○ | ○ | ○ | ○ | ○ |
| Overhead guard | If the installation is firm | Testing hammer | ○ | ○ | ○ | ○ | ○ | ○ |
| | Check for deformation, cracks, damage | | ○ | ○ | ○ | ○ | ○ | ○ |

Drive system

| Item | Service required | Tool | Daily (8h) | Weekly (40h) | Monthly (166h) | Every 3 months (500h) | Every 6 months (1000h) | Annually (2000h) |
|---------------------|---|------|------------|--------------|----------------|--|------------------------|------------------|
| Drive axle assembly | Check for abnormal noise | | ○ | ○ | ○ | ○ | ○ | ○ |
| | Check for leakage | | ○ | ○ | ○ | ○ | ○ | ○ |
| | Oil change in axle housing (gear oil) | | | | | Every 3 months for the first time, every six months thereafter | | |
| | Check for hub bearing looseness and noise | | | ○ | ○ | ○ | ○ | ○ |
| | Check axle deformation, crack or damage | | | | | ○ | ○ | ○ |

Wheels (Front, Rear Wheels)

| Item | Service required | Tool | Daily (8h) | Weekly (40h) | Monthly (166h) | Every 3 months (500h) | Every 6 months (1000h) | Annually (2000h) |
|-------|---|----------------|-----------------------|-----------------------|-----------------------|-----------------------|------------------------|-----------------------|
| Tires | Inflation pressure | Barometer | <input type="radio"/> | <input type="radio"/> | <input type="radio"/> | <input type="radio"/> | <input type="radio"/> | <input type="radio"/> |
| | Wear, cracks or damage | | <input type="radio"/> | <input type="radio"/> | <input type="radio"/> | <input type="radio"/> | <input type="radio"/> | <input type="radio"/> |
| | Check for nails, stones or other foreign objects in the tread | | | | <input type="radio"/> | <input type="radio"/> | <input type="radio"/> | <input type="radio"/> |
| | Check for damaged rims | | <input type="radio"/> | <input type="radio"/> | <input type="radio"/> | <input type="radio"/> | <input type="radio"/> | <input type="radio"/> |
| | Split type rim bolt looseness | Testing hammer | <input type="radio"/> | <input type="radio"/> | <input type="radio"/> | <input type="radio"/> | <input type="radio"/> | <input type="radio"/> |

Steering System

| Item | Service required | Tool | Daily (8h) | Weekly (40h) | Monthly (166h) | Every 3 months (500h) | Every 6 months (1000h) | Annually (2000h) |
|--------------------|---|----------------|-----------------------|-----------------------|-----------------------|-----------------------|------------------------|-----------------------|
| Steering wheel | Check play | | <input type="radio"/> | <input type="radio"/> | <input type="radio"/> | <input type="radio"/> | <input type="radio"/> | <input type="radio"/> |
| | Check axial looseness | | <input type="radio"/> | <input type="radio"/> | <input type="radio"/> | <input type="radio"/> | <input type="radio"/> | <input type="radio"/> |
| | Check radial looseness | | <input type="radio"/> | <input type="radio"/> | <input type="radio"/> | <input type="radio"/> | <input type="radio"/> | <input type="radio"/> |
| | Check operation | | <input type="radio"/> | <input type="radio"/> | <input type="radio"/> | <input type="radio"/> | <input type="radio"/> | <input type="radio"/> |
| Steering gear | Check for loose mounting bolts | | | | <input type="radio"/> | <input type="radio"/> | <input type="radio"/> | <input type="radio"/> |
| Rear wheel knuckle | Check king pin for looseness or damage | | | | <input type="radio"/> | <input type="radio"/> | <input type="radio"/> | <input type="radio"/> |
| | Check for deflection, deformation, cracks or damage | | | | <input type="radio"/> | <input type="radio"/> | <input type="radio"/> | <input type="radio"/> |
| | Check for installation | Testing hammer | | | <input type="radio"/> | <input type="radio"/> | <input type="radio"/> | <input type="radio"/> |
| Steering cylinder | Check for operation | | <input type="radio"/> | <input type="radio"/> | <input type="radio"/> | <input type="radio"/> | <input type="radio"/> | <input type="radio"/> |
| | Check for leakage | | <input type="radio"/> | <input type="radio"/> | <input type="radio"/> | <input type="radio"/> | <input type="radio"/> | <input type="radio"/> |
| | Check for looseness when installing and hinging. | | | | <input type="radio"/> | <input type="radio"/> | <input type="radio"/> | <input type="radio"/> |

Braking system

| Item | Service required | Tool | Daily (8h) | Weekly (40h) | Monthly (166h) | Every 3 months (500h) | Every 6 months (1000h) | Annually (2000h) |
|--------------------------------------|---|-------|------------|--------------|----------------|-----------------------|------------------------|------------------|
| Brake pedal | Free play | Ruler | ○ | ○ | ○ | ○ | ○ | ○ |
| | Pedal stroke | | ○ | ○ | ○ | ○ | ○ | ○ |
| | Operation | | ○ | ○ | ○ | ○ | ○ | ○ |
| | Check for air in brake lines | | ○ | ○ | ○ | ○ | ○ | ○ |
| Parking brake control | Check braking is safe and reliable, stroke is sufficient | | ○ | ○ | ○ | ○ | ○ | ○ |
| | Operating performance | | ○ | ○ | ○ | ○ | ○ | ○ |
| Rods, cables etc. | Operating performance | | | | ○ | ○ | ○ | ○ |
| | Loose connections | | | | ○ | ○ | ○ | ○ |
| | Gear box connector wear | | | | | ○ | ○ | ○ |
| Pipelines | Damage, leakage, rupture | | | | ○ | ○ | ○ | ○ |
| | Connection, clamping parts, looseness | | | | ○ | ○ | ○ | ○ |
| Master brake cylinder Wheel cylinder | Leakage | | ○ | ○ | ○ | ○ | ○ | ○ |
| | Check oil level, change oil | | ○ | ○ | ○ | | × first | × |
| | Master cylinder, wheel cylinder action | | | | | ○ | ○ | ○ |
| | Master cylinder, wheel cylinder leakage and damage | | | | | ○ | ○ | ○ |
| | Inspect master and wheel cylinder piston cups and check-valves for wear and damage, replace | | | | | | × | × |

Hydraulic system

| Item | Service required | Tool | Daily (8h) | Weekly (40h) | Monthly (166h) | Every 3 months (500h) | Every 6 months (1000h) | Annually (2000h) |
|-------------------------|---|--------------------|------------|--------------|----------------|-----------------------|------------------------|------------------|
| Hydraulic oil reservoir | Check oil level, change oil | | ○ | ○ | ○ | ○ | × First | × |
| | Clean oil filter, replace | | | | | | ○ | × |
| | Clear foreign bodies | | | | | | ○ | ○ |
| Control valve rod | Loose connections | | ○ | ○ | ○ | ○ | ○ | ○ |
| | Operation | | ○ | ○ | ○ | ○ | ○ | ○ |
| Multi-way valve | Leakage | | ○ | ○ | ○ | ○ | ○ | ○ |
| | Operation of safety valve and self-locking tilt valve | | | | ○ | ○ | ○ | ○ |
| | Measure safety valve pressure | Oil pressure gauge | | | | | ○ | ○ |
| Pipe connectors | Leaks, looseness, rupture, deformation, damage | | | | ○ | ○ | ○ | ○ |
| | Replace pipes | | | | | | ○ | × 1-2 years |
| Hydraulic pump | Check pump for leaks and noise | | ○ | ○ | ○ | ○ | ○ | ○ |
| | Check wear of pump drive gear | | | | ○ | ○ | ○ | ○ |

Lifting system

| Item | Service required | Tool | Daily (8h) | Weekly (40h) | Monthly (166h) | Every 3 months (500h) | Every 6 months (1000h) | Annually (2000h) |
|---------------------------------|---|----------------|------------|--------------|----------------|-----------------------|------------------------|------------------|
| Chain sprocket | Check chain tension, check for deformation, damage and corrosion | | ○ | ○ | ○ | ○ | ○ | ○ |
| | Lubricate chain | | | | ○ | ○ | ○ | ○ |
| | Riveting pins and looseness | | | | ○ | ○ | ○ | ○ |
| | Sprocket deformation and damage | | | | ○ | ○ | ○ | ○ |
| | Looseness of sprocket bearings | | | | ○ | ○ | ○ | ○ |
| Attachments | Check if the state is normal | | | | ○ | ○ | ○ | ○ |
| Lift and tilt cylinders | Piston rod and piston rod threading, loose connections, deformation, damage | Testing hammer | ○ | ○ | ○ | ○ | ○ | ○ |
| | Operation | | ○ | ○ | ○ | ○ | ○ | ○ |
| | Leakage | | ○ | ○ | ○ | ○ | ○ | ○ |
| | Wear and damage of pins and cylinder steel-backed bearings | | | | ○ | ○ | ○ | ○ |
| Forks | Fork damage, deformation, wear | | | | ○ | ○ | ○ | ○ |
| | Damage and wear of fork stoppers | | | | | ○ | ○ | ○ |
| | Cracking and wear of welded part of fork heel coupling | | | | ○ | ○ | ○ | ○ |
| Overhead guard and Load bracket | Installation is firm. | Testing hammer | ○ | ○ | ○ | ○ | ○ | ○ |
| | Check for deformation, cracks, damage | | ○ | ○ | ○ | ○ | ○ | ○ |
| Mast and fork carriage | Cracking and damage of welding on inner mast, outer mast and crossbars | | | | ○ | ○ | ○ | ○ |
| | The tilting cylinder bracket and the mast is poorly welded, cracked | | | | ○ | ○ | ○ | ○ |

| | | | | | | | | |
|--|----------------|--|--|------------------------|---|---|---|---|
| or damaged | | | | | | | | |
| The inner and outer mast is poorly welded, cracked or damaged | | | | ○ | ○ | ○ | ○ | ○ |
| The fork carriage is poorly welded, cracked or damaged | | | | ○ | ○ | ○ | ○ | ○ |
| Loose roller bearings | | | | ○ | ○ | ○ | ○ | ○ |
| Wear and damage of mast support bearing | | | | | | ○ | ○ | ○ |
| Looseness of mast support cover bolts | Testing hammer | | | ○ (first time only) | | ○ | ○ | ○ |
| Looseness of lift cylinder piston rod head bolts and plate bolts | Testing hammer | | | ○ (first time only) | | ○ | ○ | ○ |
| Cracking and damage of rollers, roller shafts and welding parts | | | | ○ | ○ | ○ | ○ | ○ |

7.3 Replace the key safe parts termly

- Some parts are difficult to find damage or damage through regular maintenance. In order to fully improve the safety, users should regularly replace the parts according to the following table.
- If these parts are abnormal before the replacing time, they should be replaced immediately.

| Key safe part's description | Service life (year) |
|---|----------------------------|
| Brake hose or tube | 1~2 |
| Lifting system hydraulic hose | 1~2 |
| Lifting chain | 2~4 |
| Hydraulic system high-pressure rubber hose | 2 |
| Brake fluid cup | 2~4 |
| Brake master cylinder head and dust cover | 1 |
| Hydraulic system internal seal, rubber part | 2 |
| Steering axle rubber pad | 4 |

7.4 Forklift used oil and lubrication

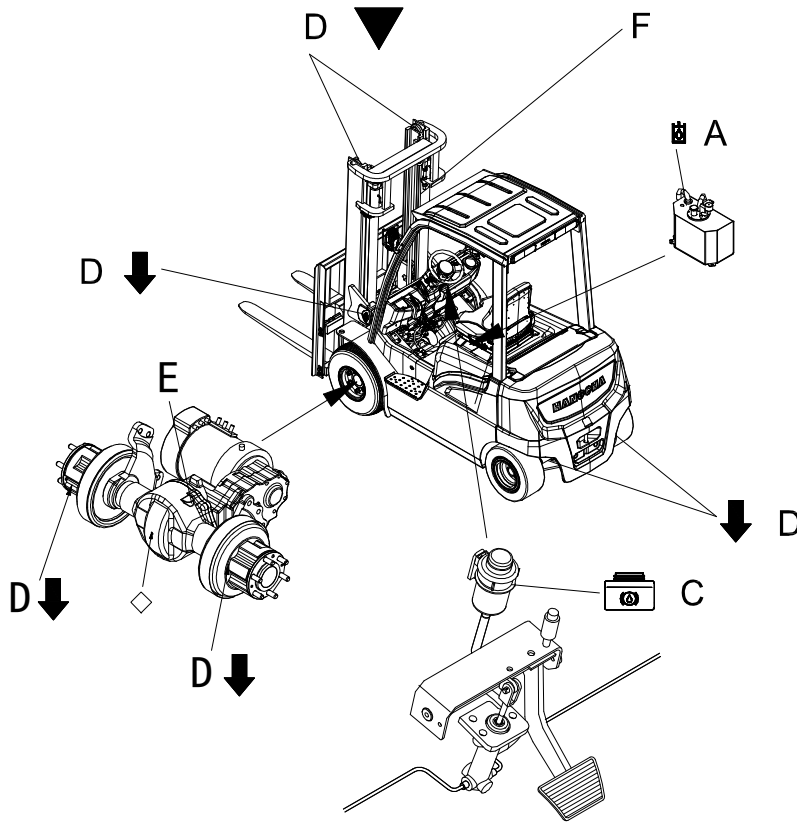

| Code | Description | Specification | Fuel charge (L) | Remark |
|------|---------------------|--|-----------------|---|
| A | Hydraulic oil | Common environment: L-HM32 Cold storage/alpine environment: L-HV32 | 35~65 | Hydraulic oil tank |
| C | Brake fluid | Choice HZY3 brake fluid (Add before delivery) or DOT3 brake fluid | ≈1.0 | Braking oiler |
| D | Lubricating grease | Automotive general purpose lithium-based grease | | Lubricating part and lubricating nozzle |
| E | Gear oil | 85W/90 (GL-5) | ≈4-8 | Drive axle and gearbox |
| F | Anti-rust oil | Chain spray or engine oil | | Chain |
| | Industrial vaseline | 2# | | Battery terminal |

Replace hydraulic oil

Hydraulic oil should be changed once a year. Vehicles in dusty environment or frequently used should be replaced half a year in advance

Steps:

- Park the truck safely.
- Tilt the mast backward to the end and drop the forks on the ground;
- Unscrew the hydraulic tank cap and dipstick assembly ;
- Place an oil pan on the lower part of the frame, unscrew the oil drain plug and the sealing washer, and drain the old oil;
- Remove the oil pan, dispose of waste oil in accordance with local environmental regulations, and do not dump it arbitrarily;
- Unscrew the oil drain plug and the sealing washer, add new hydraulic oil, and check for leakage;
- Start forklift, raise forks for 3-5 times, and tilt the mast forward or backward for 3-5 times;

Add hydraulic oil to specified scale.

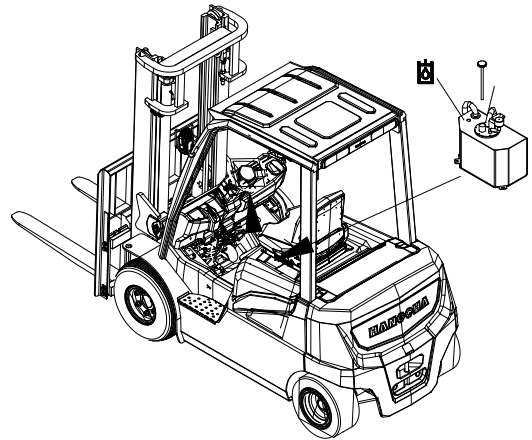

Different mast lifting heights correspond to the liquid level of the dipstick:

"30" means hydraulic height when lifting height $H \leq 3.0\text{m}$

"40" means hydraulic height when lifting height $H \leq 4.0\text{m}$

"50" means hydraulic height when lifting height $H \leq 5.0\text{m}$

"60" means hydraulic height when lifting height $H \leq 6.0\text{m}$

"65" means hydraulic height when lifting height $H \leq 6.5\text{m}$

Mast lubrication

Apply grease to the inner and outer of the mast track regularly according to the periodic maintenance and lubrication table.

In heavy or severe operating conditions, adjust lubrication intervals accordingly. During busy months, increase the number of lubricated parts.

Depending on the operation of the forklift, coat the lift guide wheel and the contact surfaces on the inner and outer sides of the mast with a layer of grease.



Warning

When adding grease, park the forklift on a flat road, turn off the electric switch and apply the parking brake. Prevent your hands and body from being caught when filling, and prevent falling when lubricating at a high position.

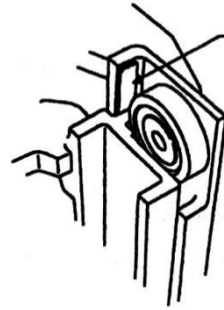
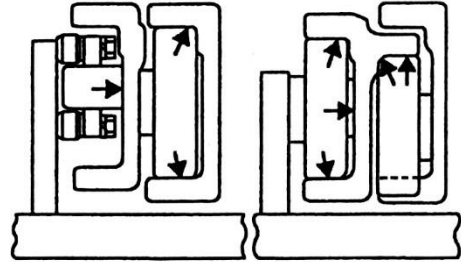

Chain lubrication

Use chain spray to spray directly on the chain or take a brush to stick engine oil to both sides of the chain

7.5 Replace wheel

When tires are worn to the limit or damaged, they should be replaced in time, and tires can only be replaced in pairs. Check that the wheel nuts are fastened after 10 hours of operation after replacing the tire.



Caution

Ensure that the replacement tires are interchangeable with the originals and must be provided by the original factory.

Replace front wheel

- Park forklift truck on level concrete. Place chocks behind rear wheels to prevent movement of forklift;
- Start the forklift, and lift the mast about 100mm. Tilt mast fully backward, and place wooden blocks under each side of the outer mast; Tilt mast forward until front wheels are raised from surface.

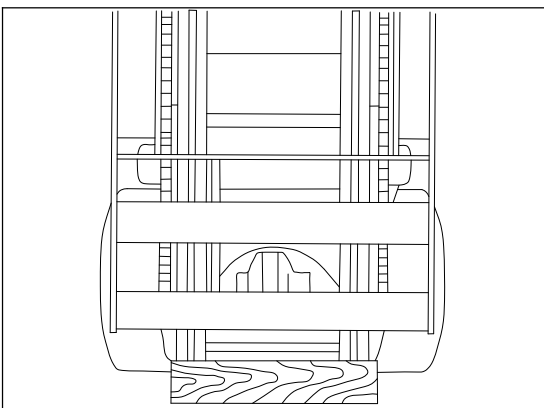

- Support truck by putting wooden blocks under both sides of the front truck frame, then turn off the key switch.

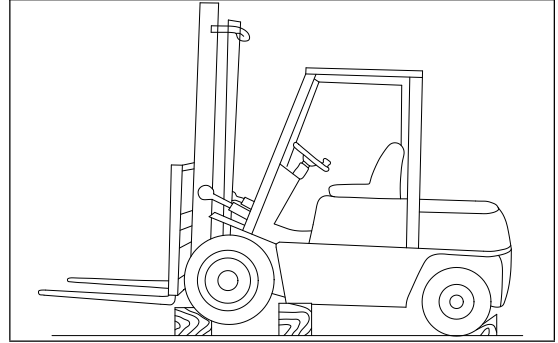

Warning

- Appropriate tools, such as wedges, hardwood supports, etc., must be used to secure to prevent the risk of accidental rolling or tipping over.
- Make sure that wooden blocks used to support forklift truck are solid, one-piece units;
- Never get under forklift while it is supported only by wooden blocks.

- Loosen the hub nuts, remove the wheel, and replace with new tires.



Warning

Do not take out wheel nuts before the rear wheels leave the ground.

Install the new tire on the hub, and screw down the hub nut symmetrically and crosswise (T=588~736N.m) .

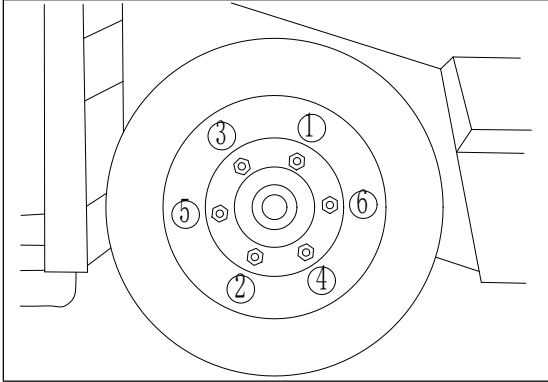

- Start the forklift, and take out wood block from the truck frame. Tilt the mast backward, slowly lower the truck, take out the wood blocks from the mast and rear wheel.

Replace rear wheel

Warning

- Only use jacks with a minimum rated load of 3000kg.
- Appropriate tools, such as wedges, hardwood supports, etc., must be used to secure to prevent the risk of accidental rolling or tipping over.

- Park forklift truck on level concrete, pull up the hand brake, place chocks behind front wheels to prevent movement of forklift.
- Put the jack at the section of the bottom counterweight, and raise the forklift with jack slowly until rear wheels off the ground.

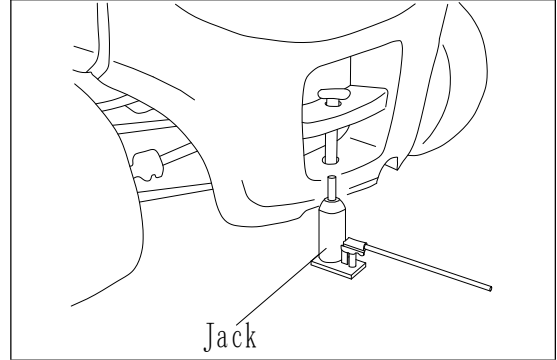

- Place a solid wood block under the truck frame.

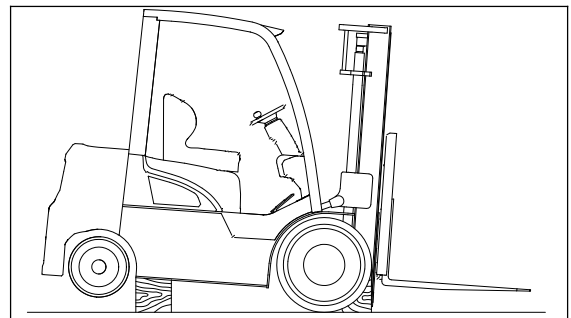

Warning

- When removing the tire from the hub, the rim bolts and nuts can only be removed after deflation;
- Make sure that wooden blocks used to support forklift truck are solid, one-piece units.
- Never get under the forklift when the forklift is only supported with wood block.

- Release hub nut, remove the wheel and replace new tire.

Warning

Do not take out wheel nuts before the rear wheels leave the ground.

- Install the new tire on the hub, and screw down the hub nut symmetrically and crosswise ($T=411\sim 588N.m$) .

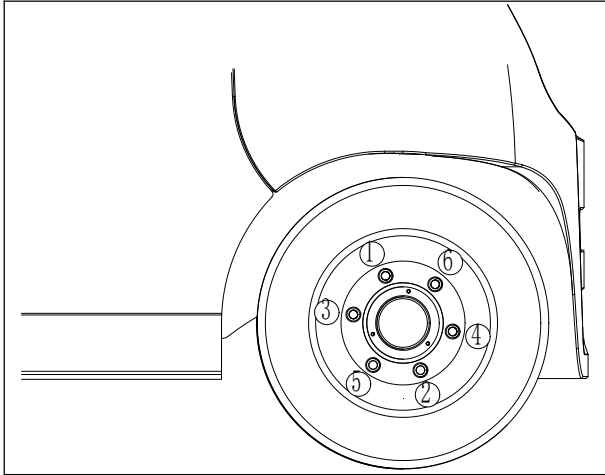

- Remove the wood block from the truck frame, lower the forklift on ground slowly, and then take away wood block and jack from the front wheel.

7.6 电器盒

Fuse parameter table

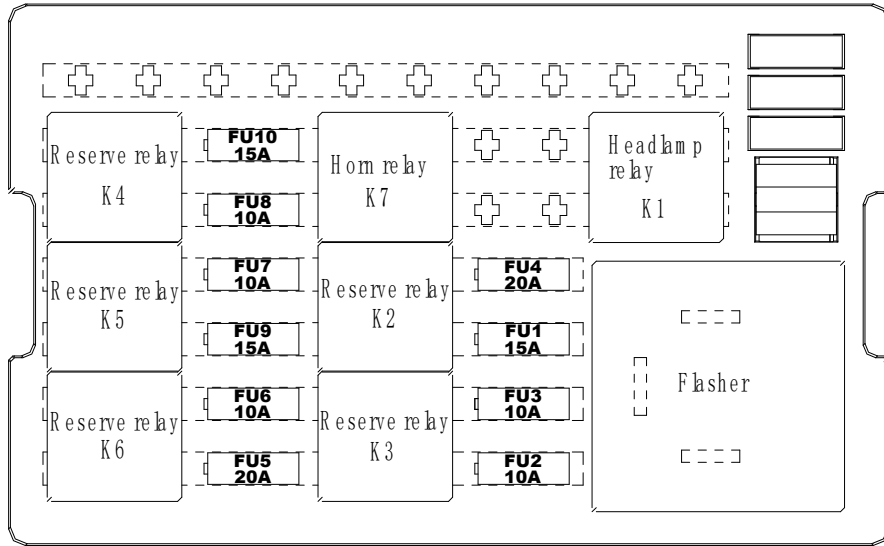

Location

Relay table

| Location | Applied parts |
|----------|---------------|
| K1 | Headlamp |
| K2 | Reserve |
| K3 | Reserve |
| K4 | Reserve |
| K5 | Reserve |
| K6 | Reserve |
| K7 | Horn |

Fuse table

| Location | Volume | Applied parts |
|----------|--------|---------------------------|
| F1 | 15A | Controller power supply |
| F2 | 10A | DC converter power supply |
| F3 | 10A | Switch power supply |

| | | |
|-----|-----|----------------------------|
| F4 | 20A | Cigar lighter power supply |
| F5 | 20A | Cab power supply |
| F6 | 10A | 24V power supply |
| F7 | 10A | Light power supply |
| F8 | 10A | Controller power supply |
| F9 | 10A | |
| F10 | 15A | Horn power supply |

Fusible line

A melted fusible line is easily observed and touched with a finger. If you are not sure if it is broken, you can test it with a multimeter or light bulb.



Caution

1. If the fusible line burns, it may be due to a short circuit (excessive power or current). Whatever the reason, double check and troubleshoot.
2. The fusible line will heat up, so do not wrap it with tape. Finally, do not place the fusible link near other wiring or parts such as rubber.



Caution

- Before working on the electrical system of the forklift, the battery plug must be unplugged.
- Before working on the electrical system of the forklift, remove metal ornaments.
- When replacing the fuse, please select a fuse with the same specifications as the fuse being replaced.

7.7 Inspection and repair of control system assembly

Procedures:

- Park the forklift safely in accordance with regulations.
Open the hood and unplug the battery.

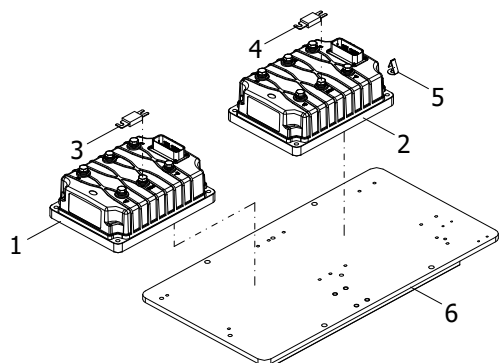

Control system assembly components

are exposed for inspection, replacement and adjustment.

| No. | Name | Control circuit |
|-----|------------------------|------------------------|
| 1 | Controller | Control drive motor |
| 2 | Controller | Control oil pump motor |
| 3 | Fuse | / |
| 4 | Fuse | / |
| 5 | Wire clip | / |
| 6 | Electric control plate | / |



Caution

- Before working on the truck electrical system, remove the battery plug.
- Controller equips with energy accumulator, do not touch between B+ and B- to avoid electric injury. To check or clean the controller, first disconnect the truck power, and then connect load(like resistance or bulb) between controller B+ and B- to discharge the capacity.
- Before checking any parts of electrical system, remove metal ornaments.
- When replacing fuse protection, please choose the one with the same specification of the replaced one.

- When repairing the controller electric control, the power must be cut off first, and then connect the positive and negative poles of the controller with a 10-100 ohm resistor to short-circuit the residual voltage on the capacitor, otherwise there is a danger of electric shock.

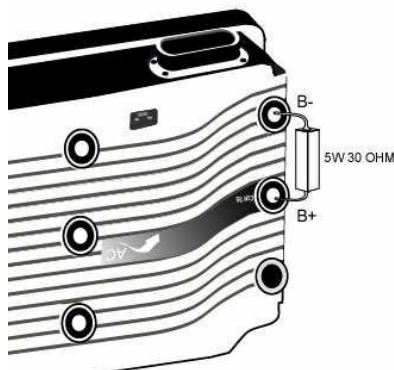

- The magnetic field and magnetic radiation of the environment have a certain influence on the normal operation of the inverter, and the long-term influence may damage the controller.

Therefore, it should be kept away from magnetic fields and magnetic radiation.

7.8 Bolt tightening torque table

Unit: N·m

| Bolt diameter | Grade | | | |
|---------------|---------|---------|---------|----------|
| | 4.6 | 5.6 | 6.6 | 8.8 |
| M6 | 4~5 | 5~7 | 6~8 | 9~12 |
| M8 | 10~12 | 12~15 | 14~18 | 22~29 |
| M10 | 20~25 | 25~31 | 29~39 | 44~58 |
| M12 | 35~44 | 44~54 | 49~64 | 76~107 |
| M14 | 54~69 | 69~88 | 83~98 | 121~162 |
| M16 | 88~108 | 108~137 | 127~157 | 189~252 |
| M18 | 118~147 | 147~186 | 176~216 | 260~347 |
| M20 | 167~206 | 206~265 | 245~314 | 369~492 |
| M22 | 225~284 | 284~343 | 343~431 | 502~669 |
| M24 | 294~370 | 370~441 | 441~539 | 638~850 |
| M27 | 441~519 | 539~686 | 637~784 | 933~1244 |

Note:

- All important joints use grade 8.8 bolts.
- Bolt's grade can be found in the head of the bolt, if it can't be found, the grade is 8.8.

8 The use, install and safety rules of attachment

HANGCHA will choose attachment that in accordance with International standard ISO2328 *Forklift pothook fork and installation size of carriage*, such as sidershifters, fork positioner, rotator, push/pull and coil boom ect.

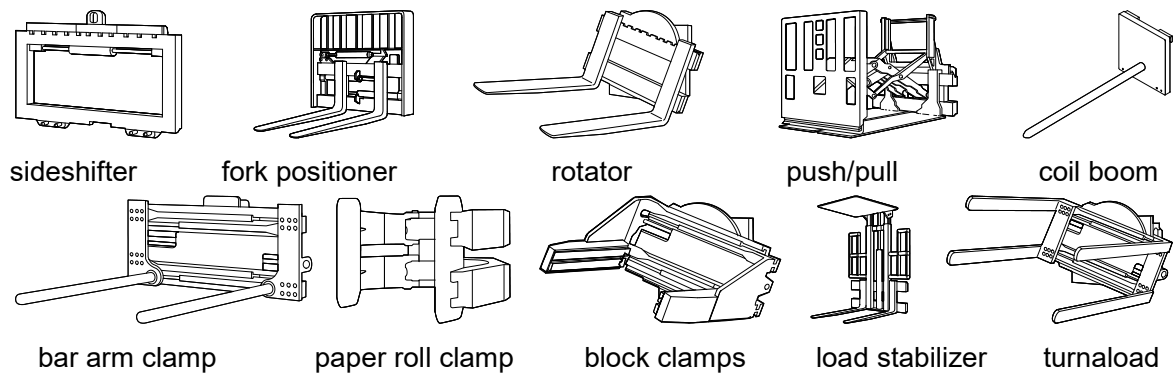

8.1 Attachment install

- Without the technical permission of the company, any modification to the safety and performance of the forklift attachment is strictly prohibited.
- Actual rating load capacity should be the least of rating load capacity, the load capacity of attachment, combined load capacity of truck. Generally speaking, the combined load capacity of truck is the least. Attachment load capacity is just a count value of attachment pressure.
- The installation and positioning are reasonable, reliable and safe to prevent the attachment from sliding left and right along the forklift frame during use.
- After the attachment is mounted, the upper hook stopper should be embedded in the gap of the upper beam, so that the offset between the centerline of the attachment and the centerline of the fork frame is less than 50mm, otherwise it will affect the lateral direction of the forklift stability.
- To these attachment with rotating function, such as paper roll clamp, bale clamp, multi-purpose clamp, drum clamp, it needs to weld chock block in the joint of carriage beam and attachment to prevent move from side to side in the operation.
- When installing the attachment with the lower hook positioning, the clearance between the lower hook and the lower beam of the fork carriage should be properly adjusted.

8.2 Attachment use

- Know well the content of nameplate on attachment, read the instruction manual before usage. (Especially the manual from attachment company) Operators of forklift attachments should be trained and qualified.
- You should fully understand the basic performance and operation methods of the forklift

attachment, especially the allowable load, lifting height, size of the cargo and the adaptable range of the attachment.

- When operating forklift attachments with multiple functions, such as with side-shifter, clamp or rotator, it is forbidden to perform two actions at the same time, and only after one action is completed, another action can be performed.
- Forklifts equipped with attachments are strictly prohibited from driving in a high cargo position; when the volume of the cargo is too large, it is forbidden to drive the forklift forward; when transporting cargo, ensure that the bottom of the cargo is 300mm off the ground and the mast is tilted backwards.
- The weight of the goods cannot exceed the limit of the combined carrying capacity of the forklift and attachments. Try not to eccentrically load at high cargo positions. For attachments with sideshift function, it can only be operated in a short time. The eccentric load is strictly controlled at 100mm on the left and right (the sideshift amount of the sideshifter above 5 tons (including 5 tons)) within the range of $\pm 150\text{mm}$).
- Except for the driver's position protected by the overhead guard, it is strictly forbidden to stand within 2 meters of the projection area directly below the attachment and the cargo to prevent accidents.
- It is not allowed that an emergency brake in moving. Run slowly with load.
- It is forbidden to be impacted by external force when the attachment is working; it is forbidden to use the attachment for improper occasions, and it must not exceed the normal working range of the attachment.
- It is forbidden to use the attachment for improper occasions, and it shall not exceed the normal working range of the attachment.
- When the attachment fails, it is prohibited to use it without exclusion.

8.3 Attachment check and maintenance

- Check the clearance between the lower beam of the forklift fork frame and the lower hook of the attachment, which meets the requirements of the attachment manual.
- Check that the upper hook is properly seated in the groove of the forklift carriage.
- Lubricate the upper and lower sliding bearing surfaces with automotive lithium grease every 500 hours.
- Whether the fasteners are loose.
- Regularly check whether the joints of the hydraulic circuit of the attachment are loose and whether the hose is damaged. If there is any damage, do not use it until it is repaired.
- Regularly check whether each transmission or rotating element of the attachment is worn or

stuck, and if damaged or defective, it needs to be replaced in time.

- In the case of dynamic load, check whether the working components of the attachment are normal, whether the working pressure of the attachment is normal, and whether the attachment is working normally. If it is not normal, you need to check the hydraulic circuit, find out the leaking components, and replace the seals or the entire loop element.

9 Related safety instruction and standard (for trucks exporting to Europe or option)

The model by CE certification which according to the following instruction and standard:

The results meet the requirements of Directive 2006/42/EC of the European Parliament and of the council on the approximation of the laws of the Member States relating to machinery、 2000/14/EC of the European Parliament and of the council on the approximation of the laws of the Member States relating to the noise emission in the environment by equipment for use outdoors、 EN ISO 3691-1:2015 , EN ISO 3691-1:2015/AC:2016 , EN ISO 3691-1:2015/A1:2020, ISO/TS 3691-7:2011, EN16307-1:2013+A1:2015,EN12053:2001+A1:2008,EN1175:2020,EN13059:2002+A1:2008 and their harmonious standards.

- Main safety factor will be according with DIRECTIVE 2006/42/EC OF THE EUROPEAN PARLIAMENT AND OF THE COUNCIL and EN ISO 3691-1:2015, ISO/TS 3691-7:2011, EN 16307-1:2013+A1:2015, EN1175: 2020 standard.
- The design and manufacture of electrical element comply with the low voltage standard 2014/35/EU.
- Noise will be according with EN12053:2001+A1:2008 and with 2000/14/EC amended by 2005/88/EC.

Sound pressure level at the operator's position is 76.1 dB(A), sound power level is 90.2 dB(A). The measurement uncertainty is 1.5 dB(A).

- Vibration parameters are measured according to standards of ISO5349-2:2001, EN13059:2002+A1:2008, ISO2631-1:1997, and the result meets the requirement of 2002/44/EC.

The whole body vibration of the seat is 0.692 m/S²

- Electromagnetism compatibility is measured according to standard of EN12895:2015 , and meets 2014/30/EU.

**DECLARATION OF CONFORMITY
EG-KONFORMITÄTSERKLÄRUNG**

*Business name of the manufacturer: Hangcha Group Co., Ltd.
Firmenbezeichnung des Herstellers:*

*Full address of the manufacturer: 666 Xiangfu Road, Lin'an District, Hangzhou City, Zhejiang Province 311305,
P.R. China*

Vollständige Adresse des Herstellers:

*Name and address of the person (established in the Community) compiled the technical file:
Name und Adresse der Person (innerhalb der Gemeinschaft), die das technische Datenblatt erstellt hat
Hangcha Europe GmbH
Mariechen-Graulich-Straße 12a, 65439 Flörsheim am Main Germany
Tel: 0049-61453769188, Andy Yang (General Manager)*

*We declare that the machinery
Wir erklären hiermit, dass die Maschine*

*product name: Electric Forklift Truck
Produktbezeichnung:*

*commercial name:
Handelsbezeichnung:*

*function:
Funktion:*

*model: CPD15/18/20/25/27/30/35/38-XCY2-SI, CPD20/25/30/35-XCY2H-SI
CPD20-XCY2-SI
Modell:*

*type:
Typ:*

*serial number: above mentioned products
Seriennummer:*

*fulfills all the relevant provisions of Directives
entspricht allen relevanten Anforderungen folgender Richtlinien*
2006/42/EC

*tested in accordance with below standards
wurde gemäß folgender Normen geprüft*

**EN ISO 3691-1:2015
EN ISO 3691-1:2015/AC:2016
EN ISO 3691-1:2015/A1:2020
EN 16307-1:2020
EN 1175:2020**

*place and date of the declaration: Hangzhou, 31.03.2021
Ausstellungsort und Datum der Erklärung*

*signature of the person:
Unterschrift des Ausstellers*

Maintenance record

| Date | Service content | Serviceman |
|------|-----------------|------------|
| | | |
| | | |
| | | |
| | | |
| | | |
| | | |
| | | |
| | | |
| | | |
| | | |
| | | |



杭叉集团股份有限公司
HANGCHA GROUP CO., LTD.

全国客服热线：400-884-7888

- 地址：中国浙江临安经济开发区相府路 666 号
- 电话：0571-88926666（总机号）85191117
- 传真：0571-85131772 ■ 邮编：311305
- 网站：<http://www.zjhc.cn> ■ 电子邮件：sales@zjhc.cn

- Address For: OVERSEAS USERS
- Address: 666 Xiangfu Road, Lin'an Economic Development Zone, Zhejiang, China
- Fax: 0086-571-88926789 0086-571-88132890 ■ ZIP:311305
- Web: <http://www.hcforklift.com> ■ E-mail: sales@hcforklift.com