

XJ 25-40 50/60 Hz

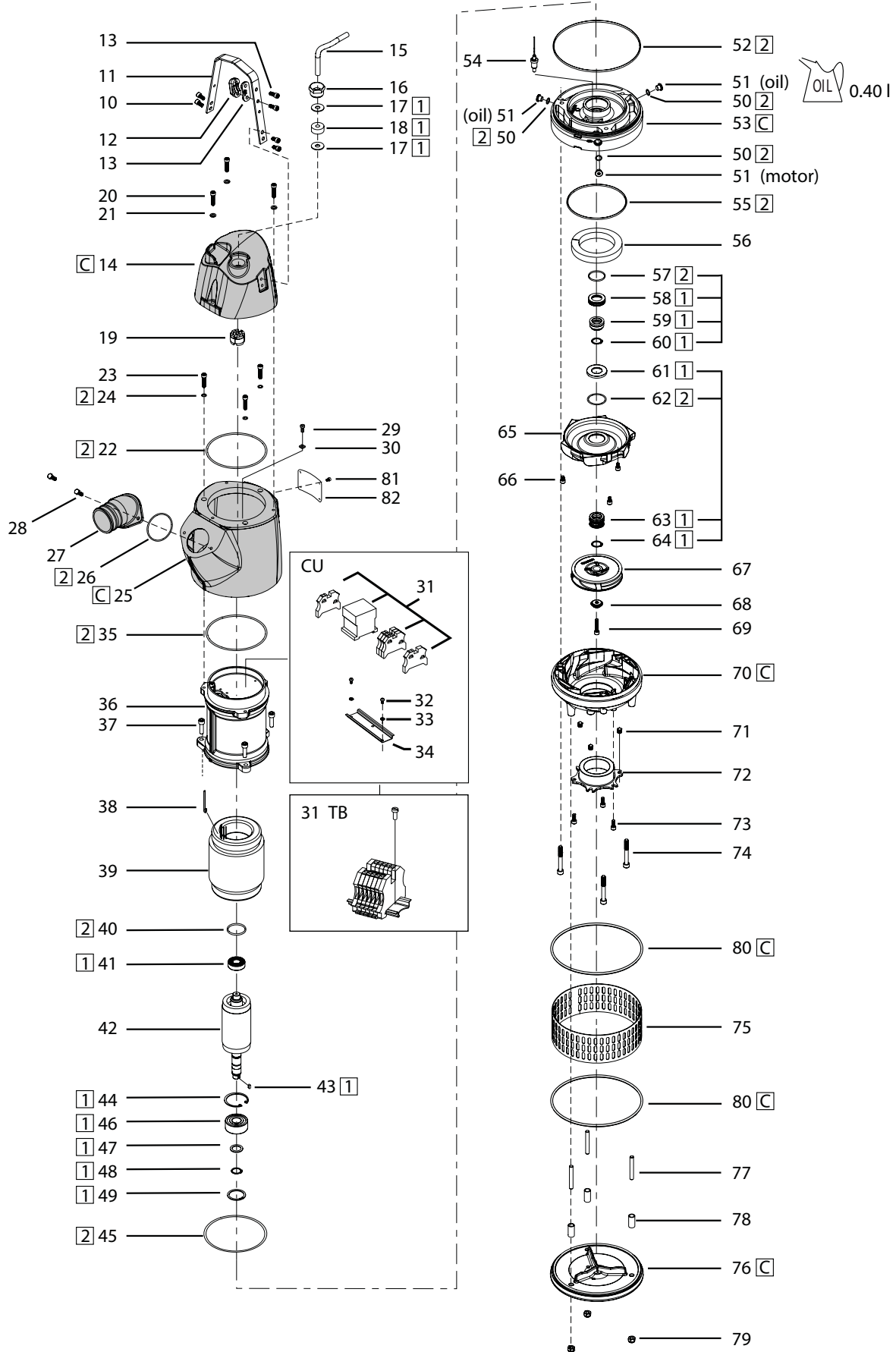

AquaTronic Version

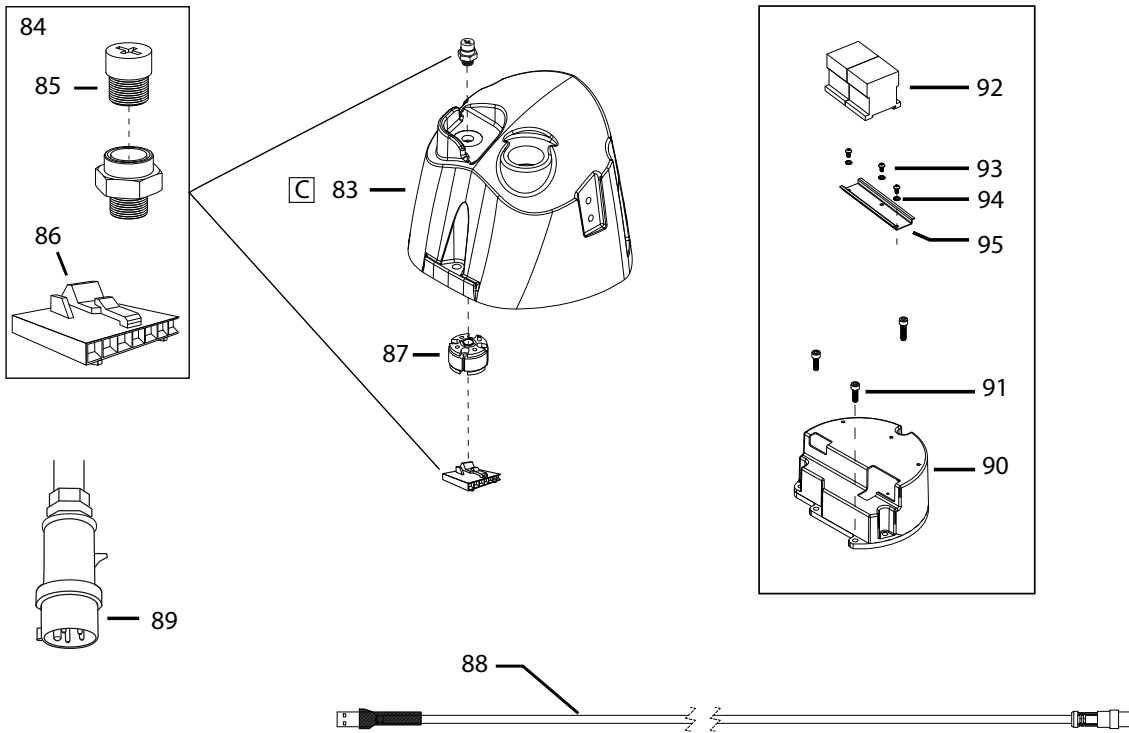

Accessories

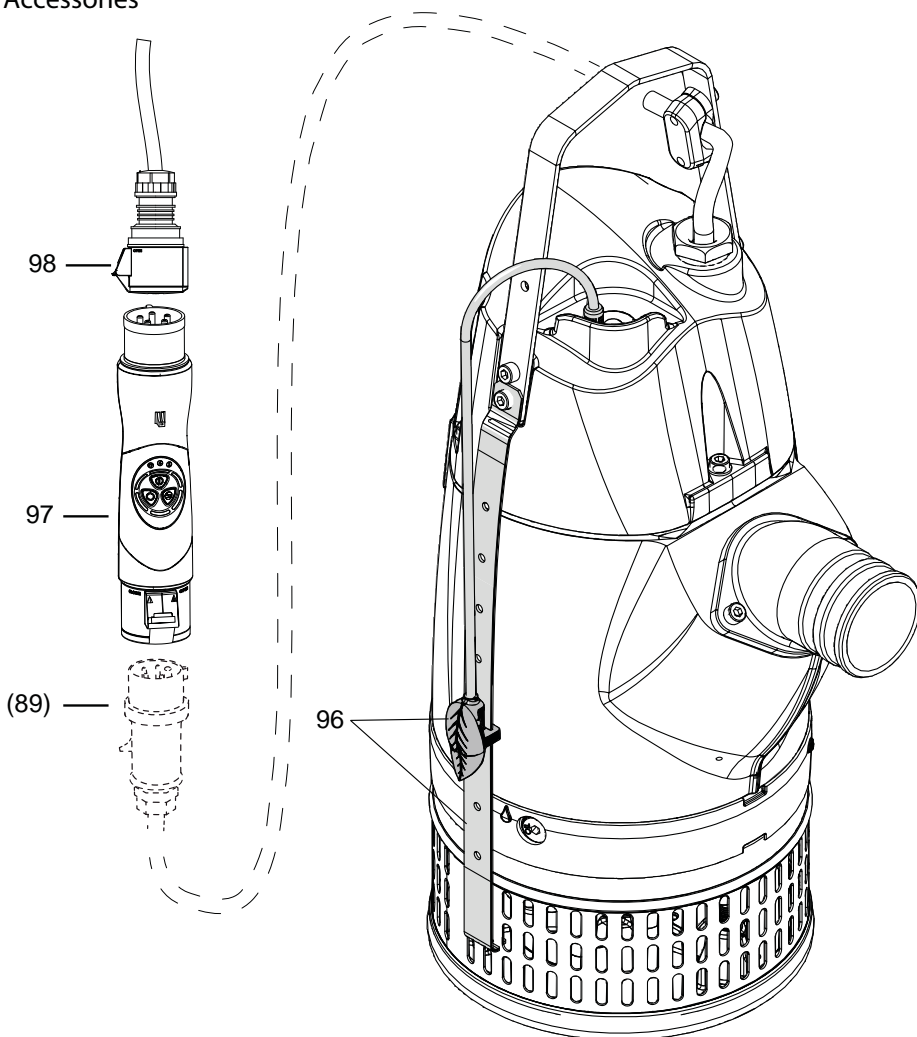

XJ 25-40 50/60 Hz

Pos nr Item No Pos.-Nr. No de repérage Posicion	Detalj nr Part No. Bestell-Nr. No de pièce Referencia	Benämning Bezeichnung	Denomination Designation Descripción	Antal Quantity Anzahl Nombre Cantidad
1	00863347	SERVICESATS KOMPL. SERVICESATZ KOMPL.	SERVICE KIT COMPL. JUEGO SERVICIO COMPL. JUEGO SERVICIO COMPL.	1
2	00863349	O-RINGSSATS (Inkluderad i pos 1) O-RINGSSATZ (in Pos 1 eingeschlossen)	O-RING KIT (included in pos 1) JEU DE JOINTS (incl. in pos 1) KIT DE JUNTAS (incl. in pos 1)	1
C	—	Rostskyddsbehandlat alternativ Korrosionsbeständige Alternative	Corrosion resistant alternative Alternative de résistant à la corrosion Alternativa de resistente a la corrosión	
10	00863152	Skruv Schraube	Screw Vis Tornillo	4
11	00863010	Handtag Handgriff	Handle Poignée Asidero	1
12	00863101	DRAGAVLASTNING KABELZUGENTLASTUNG	CABLE STRAIN RELIEF DÉCHARGE DE TRACTION DU CÂBLE PRESILLA ANTI-TIRONES DEL CABLE	1
13		S1BN8-F 4 x 1.5 mm ²		
	11210243	Skruv Schraube	Screw Vis Tornillo	2
	00863587	Dragavlastning distans Kabelzugentlastung Gegenstück	Strain relief counterpart Etrier de fermeture Suplemento de la presilla anti-tirones	1
		NSSHÖU.../3E 3x1.5+3x1.5/3E AWG 14-4 SOOW/CSA		
	11210243	Skruv Schraube	Screw Vis Tornillo	2
	00863588	Dragavlastning distans Kabelzugentlastung Gegenstück	Strain relief counterpart Etrier de fermeture Suplemento de la presilla anti-tirones	1
		NSSHÖU.../3E 3x2.5+3x2.5/3E+3x1.5 AWG 12-4 SOOW/CSA AWG 10-4 SOOW/CSA		
	00831952	Skruv Schraube	Screw Vis Tornillo	2
	00863589	Dragavlastning distans Kabelzugentlastung Gegenstück	Strain relief counterpart Etrier de fermeture Suplemento de la presilla anti-tirones	1
14	00863289	Lock Decke	Cover Couvercle Tapa	1
	00863361	Lock (rostskyddsbehandlat alternativ) Decke (Korrosionsbeständige Alternative)	Cover (corrosion resistant alternative) Couvercle (alternative de résistant à la corrosion) Tapa (alternativa de resistente a la corrosión)	1
15		KABEL KABEL	CABLE CÁBLE CABLE	1
	00832106	20 m S1BN8-F 4 x 1.5 mm ² (~Ø 10 mm)		
	00831753	20 m NSSHÖU.../3E 3x1.5+3x1.5/3E (~Ø 13 mm)		
	00831755	20 m NSSHÖU.../3E 3x2.5+3x2.5/3E+3x1.5 (~Ø 19 mm)		
	00831195	65 ft AWG 14-4 SOOW/CSA (~Ø 15 mm)		
	00831193	65 ft AWG 12-4 SOOW/CSA (~Ø 17 mm)		
	00831192	65 ft AWG 10-4 SOOW/CSA (~Ø 18 mm)		

XJ 25-40 50/60 Hz

Pos nr Item No Pos.-Nr. No de repérage Posicion	Detalj nr Part No. Bestell-Nr. No de pièce Referencia	Benämning Bezeichnung	Denomination Designation Descripción	Antal Quantity Anzahl Nombre Cantidad
16		KABELGENOMFÖRING KABELDURCHFÜHRUNG	CABLE GLAND GUIDE DE CÂBLE JUNTA DE CABLE	1
	00863168 00863070	PG 29, Ø 16 mm 8-15.5 mm PG 29, Ø 26 mm 16-26 mm		
17		BRICKA SCHEIBE	WASHER RONDELLE ARANDELA	2
	00831511	4 x 1.5 mm ² Ø 12.5 mm		
	00831393	3x1.5+3x1.5/3E Ø 14 mm		
	00830167	3x2.5+3x2.5/3E+3x1.5 Ø 20 mm		
	00830159	AWG 14-4 Ø 15.5 mm		
	00830156 00830167	AWG 12-4 Ø 18 mm AWG 10-4 Ø 20 mm		
18		KABELTÄTNING KABELDICHTUNG	CABLE SEAL MANCHON DE CÂBLE MANGUITO DE CABLE	1
	00831512	4 x 1.5 mm ² Ø 11 mm		
	00831394	3x1.5+3x1.5/3E Ø 13 mm		
	00830166	3x2.5+3x2.5/3E+3x1.5 Ø 20 mm		
	00830158	AWG 14-4 Ø 15.5 mm		
	00830155 00830166	AWG 12-4 Ø 18 mm AWG 10-4 Ø 20 mm		
19	00863209	Kabeltätning Kabeldichtung	Cable seal Manchon caotchouc Manguito de cable	1
20	00830457	Skruv Schraube	Screw Vis Tornillo	3
21	11470016	Bricka Scheibe	Washer Rondelle Arandela	3
22	00863187	O-ring O-Ring	O-ring Joint torique Junta torica	1
23	00830457	Skruv Schraube	Screw Vis Tornillo	3
24	00831637	O-ring O-Ring	O-ring Joint torique Junta torica	3
25	00863003	Mantel Mantel	Jacket Corps de pompe Carcasa exterior	1
	00863224	Mantel (rostskyddsbehandlat alternativ) Mantel (Korrosionsbeständige Alternative)	Jacket (corrosion resistant alternative) Corps de pompe (alt. de résistant à la corrosion) Carcasa exterior (alt. de resistente a la corrosión)	1
26	00830426	O-ring O-Ring	O-ring Joint torique Junta torica	1
27		TRYCKANSLUTNING ANSCHLUSS	DISCHARGE SPIGOT RACCORD CONEXION	1
	61170137	2 1/2" (Slang/Hose/Schlauch/Tuyau/Tubo)		
	61170138	3" (Slang/Hose/Schlauch/Tuyau/Tubo)		
	61170133	4" (Slang/Hose/Schlauch/Tuyau/Tubo)		
	32820519	G/BSP 2 1/2" (Gånganslutning/BSP-thread/Gewinde/Fileté/Descarga)		
	32820517	G/BSP 3" (Gånganslutning/BSP-thread/Gewinde/Fileté/Descarga)		
	32820518	G/BSP 4" (Gånganslutning/BSP-thread/Gewinde/Fileté/Descarga)		
	00830489	NPT 2 1/2" (NPT-thread/Fileté/Descarga)		
	32820520	NPT 3" (NPT-thread/Fileté/Descarga)		
	32820524	NPT 4" (NPT-thread/Fileté/Descarga)		

XJ 25-40 50/60 Hz

Pos nr Item No Pos.-Nr. No de repérage Posicion	Detalj nr Part No. Bestell-Nr. No de pièce Referencia	Benämning Bezeichnung	Denomination Designation Descripción	Antal Quantity Anzahl Nombre Cantidad
	00830344 00830345 00831945	Storz 3"/B Storz 4"/A Alv. 3" (Snabbkoppling/Kupplung) (Snabbkoppling/Kupplung) (Alvenius K10)		
28	11200126	Skruv Schraube	Screw Vis Tornillo	2
29	00863211	Skruv Schraube	Screw Vis Tornillo	1
30	00863212	Bricka Scheibe	Washer Rondelle Arandela	1
31		KONTAKTOR (INKL. SPOLE) SCHALTSCHÜTZ (INKL. SPULE)	CONTACTOR (INCL. COIL) CONTACTEUR (INCL. BOBINE) CONTACTOR (INCL. BOBINA)	1
	00863337 00863332 00863334	230 V 50 Hz 400 V 50 Hz 500 V 50 Hz		
	00863337 00863332 00863333 00863335	230 V 60 Hz 380 V 60 Hz 460 V 60 Hz 575 V 60 Hz		
	00830195	Ändstöd Endklammer	Support bracket Support Soporte	2
	00830806	Kopplingsplint 230/460 V, 60 Hz kompl. Klemmbr. 230/460 V, 60 Hz kompl.	Terminal board 230/460 V, 60 Hz compl. Plaque à bornes pour 230/460 V, 60 Hz compl. Placa de bornas en 230/460 V, 60 Hz compl.	3
	00830318	Kopplingsplint 1000 V kompl. Klemmbr. 1000 V kompl.	Terminal board 1000 V compl. Plaque à bornes pour 1000 V compl. Placa de bornas en 1000 V compl.	1
32	00863211	Skruv Schraube	Screw Vis Tornillo	2
33	00863212	Bricka Scheibe	Washer Rondelle Arandela	2
34	13430351	DIN-skena Profilschiene	Omega rail Chapeau profilé Rail	1
35	00863187	O-ring O-Ring	O-ring Joint torique Junta torica	1
36	00863005	Motorhus Motorgehäuse	Motor housing Logement du moteur Carcasa del motor	1
	00863225	Motorhus (rostskyddsbehandlat alternativ) Motorgehäuse (Korrosionsbeständige Alt.)	Motor housing (corrosion resistant alternative) Logement du moteur (alt. de résistant à la corrosion) Carcasa del motor (alt. de resistente a la corrosión)	1
37	00863153	Skruv Schraube	Screw Vis Tornillo	3
38		TEMPERATURVAKT TERMOSCHALTER	THERMAL SWITCH MICRO-CONTACTEUR TERMICO	
	-	NTC B57164K473J		2
	-	Thermik S06 140°C		2

XJ 25-40 50/60 Hz

Pos nr Item No Pos.-Nr. No de repérage Posicion	Detalj nr Part No. Bestell-Nr. No de pièce Referencia	Benämning Bezeichnung	Denomination Designation Description	Antal Quantity Anzahl Nombre Cantidad
39		STATOR STATOR	STATOR STATOR ESTATOR	1
		XJ 25		
	00863119	230 V 3~ 50 Hz		
	00863121	400 V 3~ 50 Hz		
	00863122	500 V 3~ 50 Hz		
	00863123	1000 V 3~ 50 Hz		
		XJ 40		
	00863118	230 V 3~ 60 Hz		
	00863120	380 V 3~ 60 Hz		
	00863121	460 V 3~ 60 Hz		
	00863122	575 V 3~ 60 Hz		
	00863295	230/460 V 3~ 60 Hz		
		XJ 40		
	00863125	230 V 3~ 50 Hz		
	00863127	400 V 3~ 50 Hz		
	00863128	500 V 3~ 50 Hz		
	00863129	1000 V 3~ 50 Hz		
		XJ 40		
	00863124	230 V 3~ 60 Hz		
	00863126	380 V 3~ 60 Hz		
	00863127	460 V 3~ 60 Hz		
	00863128	575 V 3~ 60 Hz		
	00863296	230/460 V 3~ 60 Hz		
40	11120893	O-ring O-Ring	O-ring Joint torique Junta torica	1
41	00863160	Kullager, övre Kugellager, oben	Ball bearing, upper Roulement, supérieur Rodamiento, superior	1
42		ROTOR MED AXEL ROTOR MIT WELLE	ROTOR WITH SHAFT ROTOR AVEC ARBRE ROTOR Y EJE	1
	00863034	XJ 25		
	00863035	XJ 40		
43	11630109	Plattkil Flachkeil	Flat key Clavette Chaveta	1
44	11070069	Låsring Nutring	Circlip Circlips Anillo de seguridad	1
45	00863188	O-ring O-Ring	O-ring Joint torique Junta torica	1
46	00863265	Kullager, nedre Kugellager, unten	Ball bearing, lower Roulement, inférieur Rodamiento, inferior	1
47	11060006	Bricka Scheibe	Washer Rondelle Arandela	1
48	11070067	Låsring Nutring	Circlip Circlips Anillo de seguridad	1
49	11070066	Låsring Nutring	Circlip Circlips Anillo de seguridad	1
50	11120894	O-ring (inkluderad i pos 53) O-Ring (in Pos 53 eingeschlossen)	O-ring (included in item 53) Joint torique (incl. dans pos 53) Junta torica (incl. en pos 53)	3

XJ 25-40 50/60 Hz

Pos nr Item No Pos.-Nr. No de repérage Posicion	Detalj nr Part No. Bestell-Nr. No de pièce Referencia	Benämning Bezeichnung	Denomination Designation Descripción	Antal Quantity Anzahl Nombre Cantidad
51	00863143	Inspektions-/Olje-plugg (inkluderad i pos 53) Verschluß-/Ölloch-schraube (in Pos 53 eingeschlossen)	Inspection/Oil plug (included in item 53) Bouchon d'inspection/d'huile (incl. dans pos 53) Tornillo de inspección/ Tapón aceite (incl. en pos 53)	3
52	00863189	O-ring O-Ring	O-ring Joint torique Junta torica	1
53		LAGERHUS SATS (inkl. 50, 51, 54, 55) LAGERGEHÄUSE SATZ (inkl. 50, 51, 54, 55)	BEARING HOUSE KIT (incl. 50, 51, 54, 55) KIT LOGEMENT DE ROULEMENT (incl. 50, 51, 54, 55) KIT DE CARCASA RODAMIENTO (incl. 50, 51, 54, 55)	
	00863695	Lagerhus Lagergehäuse	Bearing house Logement de roulement Carcasa rodamiento	1
	00863794	Lagerhus (rostskyddsbehandlat alternativ) Lagergehäuse (Korrosionsbeständige Altern.)	Bearing house (corrosion resistant alternative) Logement de roulement (alt. de résistant à la corrosion) Carcasa rodamiento (alt. de resistente a la corrosión)	1
54	00863022	Läckagevakt (inkluderad i pos 53) Di-Elektrode (in Pos 53 eingeschlossen)	Leakage monitor (included in item 53) Détecteur d'étanchéité (incl. dans pos 53) Guardia gotear (incl. en pos 53)	1
55	00863187	O-ring (inkluderad i pos 53) O-Ring (in Pos 53 eingeschlossen)	O-ring (included in item 53) Joint torique (incl. dans pos 53) Junta torica (incl. en pos 53)	1
56	00863025	Skum, gummi Schaum, Gummi	Foam, rubber Mousse en plastique Espuma de goma	1
57	11121012	O-ring O-Ring	O-ring Joint torique Junta torica	1
58	00863012	Tätningssäte, sekundärtätning Dichtungssitz, Sekundärdichtung	Holding ring, secondary seal Siège de garniture, étanchéité secondaire Anillo, junta secundario	1
59	00863008	Sekundärtätning Sekundärdichtung	Secondary seal Etanchéité secondaire Junta secundario	1
60	11070067	Låsring Nutring	Circlip Circlips Anillo de seguridad	1
61	00863214	Tätningssäte Dichtungssitz	Holding ring Siège de garniture Anillo	1
62	00863144	O-ring O-Ring	O-ring Joint torique Junta torica	1
63	00863243	Primärtätning Primärdichtung	Primary seal Etanchéité primaire Junta primario	1
64	00863244	Låsring Nutring	Circlip Circlips Anillo de seguridad	1
65	00863109	Diffusor, övre Diffusor, oben	Diffuser, upper Diffuseur, supérieur Difusor, superior	1
66	00863154	Skruv Schraube	Screw Vis Tornillo	3

XJ 25-40 50/60 Hz

Pos nr Item No Pos.-Nr. No de repérage Posicion	Detalj nr Part No. Bestell-Nr. No de pièce Referencia	Benämning Bezeichnung	Denomination Designation Descripción	Antal Quantity Anzahl Nombre Cantidad	
67		PUMPHJUL LAUFRAD	IMPELLER ROUE IMPULSOR	1	
		XJ 25			
		00863046 00863049 00863047 00863050	ND 50 Hz HD 50 Hz ND 60 Hz HD 60 Hz		
		XJ 40			
		00863052 00863054 00863046 00863049	ND 50 Hz HD 50 Hz ND 60 Hz HD 60 Hz		
	68	00863089	Pumphjulsbricka Laufradscheibe	Impeller washer Rondelle de roue Arandela de impulsor	1
	69	00863194	Skruv Schraube	Screw Vis Tornillo	1
	70		DIFFUSOR, NEDRE DIFFUSOR, UNTEN	DIFFUSER, LOWER DIFFUSEUR, INFÉRIEUR DIFUSOR, INFERIOR	1
			XJ 25 - 40 ND HD		
			Diffusor, nedre (rostskyddsbehandl. alternativ) Diffusor, unten (Korrosionsbest. Alternative)	Diffuser, lower (corrosion resistant alternative) Diffuseur, inférieur (alt. de résistant à la corrosion) Difusor, inferior (alt. de resistente a la corrosión)	1
		XJ 25 - 40 ND HD			
71	00863158	Skruv Schraube	Screw Vis Tornillo	3	
72		SLITRING VERSCHLEISSRING	WEAR RING BAGUE D'USURE ANILLO DE DESGASTE	1	
		00863066 00863067	ND HD		
73	00830518	Skruv Schraube	Screw Vis Tornillo	3	
74	00863155	Skruv Schraube	Screw Vis Tornillo	3	
75	00863011	Sil Sieb	Strainer Crépine Coladera	1	
76	00863009	Bottenplatta Bodenplatte	Base Plate Plaque de base Placa de base	1	
	00863231	Bottenplatta (rostskyddsbehandlat alternativ) Bodenplatte (Korrosionsbeständige Altern.)	Base Plate (corrosion resistant alternative) Plaque de base (alt. de résistant à la corrosion) Placa de base (alternativa de resistente a la corrosión)	1	
	00863371	Pinnbult Stiftschraube	Stud bolt Boulon prisonnier Espárrago	3	

XJ 25-40 50/60 Hz

Pos nr Item No Pos.-Nr. No de repérage Posicion	Detalj nr Part No. Bestell-Nr. No de pièce Referencia	Benämning Bezeichnung	Denomination Designation Descripción	Antal Quantity Anzahl Nombre Cantidad
78	00863173	Distanshylsa Distanzhülse	Distance sleeve Douille à distance Distancia de la manga	3
	00863246	Distanshylsa (rostskyddsbehandlat alternativ) Distanzhülse (Korrosionsbeständige Altern.)	Distance sleeve (corrosion resistant alternative) Douille à distance (alt. de résistant à la corrosion) Distancia de la manga (alt. de resist. a la corrosión)	3
79	11400055	Låsmutter Sicherungsmutter	Lock nut Ecrou de blockage Tuerca	3
80	00863174	Kantskydd (rostskyddsbehandlat alternativ) Kantenschutz (Korrosionsbest. Alternative)	Edge protection (corrosion resistant alternative) Protection des bords (alt. de résistant à la corrosion) Protección de bordes (alt. de resistente a la corrosión)	2
81	11550015	Drivskruv Tribschraube	Drive screw Goujon Tornillo	4
82	contact Sulzer	Skylt Datenschild	Nameplate Plaque Placa	1
		AQUATRONIC VERSION AQUATRONIC VERSION	AQUATRONIC VERSION AQUATRONIC VERSION AQUATRONIC VERSIÓN	
83	00863001	Lock Decke	Cover Couvercle Tapa	1
	00863223	Lock (rostskyddsbehandlat alternativ) Decke (Korrosionsbeständige Alternative)	Cover (corrosion resistant alternative) Couvercle (alternative de résistant à la corrosion) Tapa (alternativa de resistente a la corrosión)	1
84	00863320	Sats - AquaTronic kontakt (inkl. lock, o-ring, kabel, kontakt) Satz - AquaTronic Steckverbinder (inkl. Lock, O-Ring, Kabel, Stecker)	Kit - AquaTronic connector (incl. cap, o-ring, cable, connector) Équipement - AquaTronic connecteur (incl. couvercle, joint torique, câble, connecteur) Kit - AquaTronic conector (incl. tapa, junta torica, cable, conector)	1
85	00863294	Lock, AquaTronic kontakt (Inkl. i sats) Deckel, AquaTronic Steckverbinder (in Satz eingeschlossen)	Cap, AquaTronic connector (included in kit) Couvercle, AquaTronic connecteur (incl. in équipement) Tapa, AquaTronic conector (incl. in kit)	1
86	00863377	Kontakt (inkluderad i sats) Stecker (in Satz eingeschlossen)	Connector (included in kit) Connecteur (incl. in équipement) Conector (incl. in kit)	1
87	00863210	Kabeltätning Kabeldichtung	Cable seal Manchon caotchouc Manguito de cable	1
88	00863329	AquaTronic kommunikationskabel AquaTronic Kommunikationskabel	AquaTronic communication cable AquaTronic câble de communication AquaTronic cable de comunicación	1
89		STICKPROPP STECKER	PLUG FICHE CLAVIJA DE CONEXIÓN	1
	00863429	XJ 25, XJ 40 CEE 16 A, 230 V 50/60 Hz, 3~		
	13100003	CEE 16 A, 400 V 50 Hz, 380 V 60 Hz, 3~		
	00863430	CEE 16 A, 500 V 50 Hz, 460 V 60 Hz, 3~		
	00863431	CEE 16 A, 575 V 60 Hz, 3~		

XJ 25-40 50/60 Hz

Pos nr Item No Pos.-Nr. No de repérage Posicion	Detalj nr Part No. Bestell-Nr. No de pièce Referencia	Benämning Bezeichnung	Denomination Designation Descripción	Antal Quantity Anzahl Nombre Cantidad
90		AQUATRONIC AQUATRONIC	AQUATRONIC AQUATRONIC AQUATRONIC	1
	00863148	12A DS 230-575 V 50/60 Hz		
91	00863170	Skruv Schraube	Screw Vis Tornillo	3
92		KONTAKTOR (INKL. SPOLE) SCHALTSCHÜTZ (INKL. SPULE)	CONTACTOR (INCL. COIL) CONTACTEUR (INCL. BOBINE) CONTACTOR (INCL. BOBINA)	
	00863220	XJ 25 230-500 V 50 Hz, 230-575 V 60 Hz XJ 40 400-500 V 50 Hz, 380-575 V 60 Hz Kontaktor (inkl. spole) Schaltschütz (inkl. Spule)	Contacteur (incl. bobine) Contacteur (incl. bobine) Contacteur (incl. bobine)	1
	00863318	XJ 40 230 V 50 Hz, 230 V 60 Hz Kontaktor (inkl. spole) Schaltschütz (inkl. Spule)	Contacteur (incl. bobine) Contacteur (incl. bobine) Contacteur (incl. bobine)	1
	00863299	Relä Relais	Relay Relais Relé	1
93	00832254	Skruv Schraube	Screw Vis Tornillo	3
94	11510014	Bricka Scheibe	Washer Rondelle Arandela	3
95	00863090	DIN-skena Profilschiene	Omega rail Chapeau profilé Rail	1
		TILLBEHÖR ZUBEHÖR	ACCESSORIES ACCESSOIRES ACCESORIOS	
96	00863196	Sats - Nivådränksond Satz - Niveau Eintauchsonde	Kit - Level sensor Équipement - Détecteur de niveau, Kit - Sensor de nivel	1
	00863104	Nivådränksond (inkluderad i sats) Niveau Eintauchsonde (in Satz eingeschlossen)	Level sensor (included in kit) Détecteur de niveau (incl. in équipement) Sensor de nivel (incl. in kit)	1
	00863186	Fäste (inkluderad i sats) Halterung (in Satz eingeschlossen)	Bracket (included in kit) Support (incl. in équipement) Soporte (incl. in kit)	1
97		AQUAPLUG AQUAPLUG	AQUAPLUG AQUAPLUG AQUAPLUG	1
	00863365	208-230 V, 16 A		
	00863366	208-230 V, 32 A		
	00863184	380-415 V, 16 A		
	00863288	380-415 V, 32 A		
	00863542	460-550 V, 16 A		
	00863543	460-550 V, 32 A		
	00863369	575-600 V, 16 A		
	00863370	575-600 V, 32 A		

XJ 25-40 50/60 Hz

Pos nr Item No Pos.-Nr. No de repérage Posicion	Detalj nr Part No. Bestell-Nr. No de pièce Referencia	Benämning Bezeichnung	Denomination Designation Descripción	Antal Quantity Anzahl Nombre Cantidad
---	---	--------------------------	--	---

98		AQUAPLUG ADAPTERENHET AQUAPLUG ADAPTEREINHEIT	AQUAPLUG ADAPTER UNIT AQUAPLUG UNITÉ D'ADAPTATION AQUAPLUG ADAPTADOR DE UNIDAD	1
	00863311	208-230 V, 16 A		
	00863312	208-230 V, 32 A		
	00863308	380-415 V, 16 A		
	00863309	380-415 V, 32 A		
	00863313	460-550 V, 16 A		
	00863314	460-550 V, 32 A		
	00863315 00863316	575-600 V, 16 A 575-600 V, 32 A		
	00863179	Zinkanodbandsats Zinkannodenbändersatz	Zinc anode belt kit Ceinture d'anodes en zinc Cinturión con ánodos de zinc	1
		SERIEKÖPPLING KOMPLETT SERIENKUPPLNG KOMPLETT	SERIES CONNECTION COMPLETE RACCORD D'ACCOUPLMENT COMPLET CONEXIÓN EN SERIE COMPLET	1
	00863325	3"		
	00863326	4"		
		Stickpropp - se position 89 Stecker - siehe Position 89	Plug - see position 89 Fiche - voir la position 89 Clavija de conexión - ver la posición 89	1

XJ 25-40 50/60 Hz

Pos nr	Detalj nr	Benämning	Denomination	Antal
Item No	Part No.	Bezeichnung	Designation	Quantity
Pos.-Nr.	Bestell-Nr.		Descripcion	Anzahl
No de repérage	No de pièce			Nombre
Posicion	Referencia			Cantidad
